

**NPL REPORT
DEPC-MPR 017**

**Investigations into Sensation
of “Softness” and Perception
of the Tactile Properties of
“Soft Touch” Thermoplastic
Elastomers**

**H Petrie, N King and
P Tomlins**

NOT RESTRICTED

DECEMBER 2004



The DTI drives our ambition of 'prosperity for all' by working to create the best environment for business success in the UK. We help people and companies become more productive by promoting enterprise, innovation and creativity.

We champion UK business at home and abroad. We invest heavily in world-class science and technology. We protect the rights of working people and consumers. And we stand up for fair and open markets in the UK, Europe and the world.

The National Physical Laboratory is operated on behalf of the DTI by NPL Management Limited, a wholly owned subsidiary of Serco Group plc

Investigations into Sensation of “Softness” and Perception of the Tactile Properties of “Soft Touch” Thermoplastic Elastomers

H Petrie¹, N King¹ and P Tomlins²

¹ Centre for Human-Computer Interaction Design
City University, Northampton Square
London, EC1V 0HB

² Engineering and Process Control Division
National Physical Laboratory
Teddington, Middlesex, UK, TW11 0LW

ABSTRACT

Three studies were undertaken to provide initial objective data on the psychological perception of soft plastic materials. In the first study, a vocabulary elicitation study, 105 participants (representing a wide range of characteristics – age, gender, ethnicity, sensory impairment) were asked to produce any words to describe the characteristics of a set of samples of soft touch thermoplastic elastomers. These words were then used in a card sort study in which a further 10 participants were asked to sort cards with the words typed on them into as many piles as they liked, with similar words in each pile. This study yielded 7 clusters of words, representing the key psychological dimensions of the perception of soft touch thermoplastic elastomers: femininity, pleasantness, elasticity, masculinity, uncomfoting, robustness and malleability. Finally, the third study investigated the psychophysics of the relationship between physical characteristics and the psychological perception of a set of samples. The magnitude estimation method was used, with participants assessing the softness/smoothness of samples in comparison to the softness/smoothness of a modulus sample. The results showed a highly significant relationship between the perception of softness of the soft touch thermoplastic elastomers and their Shore A hardness values, that was unaffected by the thickness or shape of the samples. No significant relationship was found between the perception of the smoothness of the soft touch thermoplastic elastomers and their Shore A hardness values. The implications of these results are discussed.

© Crown copyright 2005
Reproduced with the permission of the Controller of HMSO
and Queen's Printer for Scotland

ISSN 1744-0270

National Physical Laboratory
Hampton Road, Teddington, Middlesex, TW11 0LW

Extracts from this report may be reproduced provided the source is acknowledged and the extract is not taken out of context.

We gratefully acknowledge the financial support of the UK Department of
Trade and Industry (National Measurement System Policy Unit)

Approved on behalf of the Managing Director, NPL,
by Dr M G Cain, Knowledge Leader, Materials Processing Team
authorised by Director, Engineering and Process Control Division

CONTENTS

1	INTRODUCTION	2
2	DEFINITIONS OF HARDNESS AND SOFTNESS	2
3	MATERIALS AND PHYSICAL MEASUREMENTS.....	3
3.1	MATERIALS	3
3.2	HARDNESS MEASUREMENTS	3
4	DEVELOPMENT OF THE VOCABULARY FOR DESCRIBING THE TACTILE PROPERTIES.....	5
4.1	VOCABULARY ELICITATION STUDY	5
4.1.1	<i>Participants</i>	5
4.1.2	<i>Procedure</i>	5
4.1.3	<i>Results</i>	6
4.2	CARD SORTING STUDY	6
4.2.1	<i>Participants</i>	7
4.2.2	<i>Words Used</i>	7
4.2.3	<i>Procedure</i>	7
4.2.4	<i>Data Analysis</i>	7
4.2.5	<i>Results</i>	7
5	DETERMINATION OF PSYCHOPHYSICAL RELATIONSHIPS.....	9
	METHOD	10
5.1	PARTICIPANTS	10
5.2	MATERIALS	10
5.3	PROCEDURE.....	10
5.4	RESULTS	13
6.	DISCUSSION AND CONCLUSIONS.....	15
7	ACKNOWLEDGEMENTS.....	17
8	REFERENCES.....	17
	APPENDIX 1 – A BRIEF INTRODUCTION TO THE PSYCHOLOGY OF TOUCH.....	20
A1.1	INTRODUCTION	20
A1.2	THE HAPTIC SYSTEM.....	20
A1.2.1	<i>Geometric properties</i>	21
A1.2.2	<i>Material properties</i>	22
A1.2.3	<i>Psychophysics</i>	22
A1.2.4	<i>Established methodologies</i>	23
	APPENDIX 2: FREQUENCY OF TERMS.....	26
	APPENDIX 3: UNIQUE TERMS FOR CARD SORT EXERCISE	29
	APPENDIX 4: DENDROGRAM OF CLUSTERS	30

1 INTRODUCTION

Our perception of something, for example an attribute of an object, provides data for decision-making; do I think this product is worth the money? Is this sofa going to be comfortable to sit on? Does the colour suit me? Understanding this link between our perception of something and its physical characteristics can be commercially exploited by providing potential customers with, for example, the appropriate sensory triggers that will result in a purchase. To achieve this objective, the subjective information provided by members of a sensory panel needs to be quantified noting that our interpretation of the bundle of sensory information that we process is more often than not influenced by our past experiences of similar situations, materials or objects. This can be achieved by asking volunteers to quantify their perceptions of an object based on an arbitrary scale using a set of adjectives that elicit the same understanding amongst the group. This presents two problems:

- Which group of adjectives have common meanings for people who may be of different sexes, ages and cultural backgrounds?
- How should the tests be conducted in order to reduce the experimental uncertainty in the resultant data?

This investigation seeks to provide answers to these questions and to establish a psychophysical link between the perception of a range of ‘soft-touch’ rubber-like materials and a measured Shore hardness.

‘A soft-touch feeling is difficult to quantify by test methods and is largely subjective’ (DEX Plastomers, 2000). This statement is typical of the view of manufacturers of products where the ‘feel factor’ plays an important role in the customers perception of quality. However, this view fails to consider the possibilities of using psychophysical methods to objectify and quantify the relationships between the properties of objects and their perception.

During the past eight to ten years the concept of soft-touch feel has been applied to plastic mouldings. The most common class of materials are the thermoplastic elastomers, copolymers of elastomer and thermoplastic that can be moulded using conventional plastics processing equipment. Typically thermoplastic elastomers are over moulded over ‘conventional’ plastic skeletons made from, for example, polyethylene or polystyrene. The overmoulded layer has a rubbery feel to it that is much softer than can be achieved by thermoplastics alone. Thermoplastic elastomers offer significant advantages over using rubbers or PVC films: processing is simpler and the product is recyclable. This gives opportunities for cost savings and a considerably simpler route to complying with the recycling directives.

2 DEFINITIONS OF HARDNESS AND SOFTNESS

The term “softness” is loosely used to describe the physical as well as sensory attributes of materials. Usually the softness of a material is taken to be a measure of compressibility but softness in a sensory sense is much more complicated than this and also involves contributions from surface texture, thermal conductivity and friction. Physically soft materials do not necessarily have the most desirable characteristics of soft materials in a sensory sense: compare the feel of a rotting melon with a feather pillow. It is this difference that is the key issue in characterising soft-touch materials in general and in particular soft-touch plastics.

The overall sensation of softness can refer to surface softness or bulk softness or some complex combination of the two. The surface softness is a measure of the *smoothness* of a surface. Bulk softness is a measure of the *compressibility* of a material. Materials such as wood can have high values of surface softness and minimal bulk softness whereas a feather pillow will have both significant levels of bulk and surface softness. Bulk softness is essentially the inverse of hardness. Hardness is a commonly used measure of the physical response of a material to penetration of an indenter with a defined geometry. The magnitude of this physical property depends on the test conditions used i.e. the dwell time, indentation speed and on the geometry of the specimen and therefore hardness is not a fundamental material property. Hardness data for rubbers are usually based on measuring the initial indentation, or the indentation after some elapsed time or both. Indentation hardness is inversely related to the penetration and depends on the Young's modulus and the viscoelastic properties of the material: properties that are both time- and temperature dependent.

Our ability to perceive the softness, and other properties, of an object is related to our haptic senses; these include the cutaneous or tactile receptors located within the skin which provide tactile feedback, and kinesthetic receptors which receive sensory inputs from the body's muscle tendons and joints, indicating the position of our limbs, thus providing force feedback (for further information about the psychology and psychophysics of haptics, see Appendix 1).

3 MATERIALS AND PHYSICAL MEASUREMENTS

3.1 MATERIALS

Styrene-ethylene-butlyene–styrene, (SEBS), is a thermoplastic elastomer used in applications that require a 'soft-touch' finish. The material can be injection moulded to form objects or used as an over-moulded coating on other materials, i.e. hard plastics, to provide a soft finish. Different formulations of this material are available that span the Shore A hardness scale¹, see Table 1. Square sheets of dimensions 150 mm by 150 mm and either 2.6 mm or 3.9 mm thick were manufactured by injection moulding using conditions that have been described elsewhere (Tomlins et al, in prep).

3.2 HARDNESS MEASUREMENTS

The deformation produced by applying a known force to an indenter for a specific time is commonly used to measure the physical hardness of polymers, composites and similar materials. Figure 1 shows a schematic representation of a typical indenter which terminates in a truncated cone. Each 0.001 inch of indentation into the material corresponds to 1 degree Shore on the A scale. Samples that have hardnesses below 10 degrees or above 90 degrees are measured on different scales, the O and D respectively. Details of the test method are to be found in ASTM D 2240-04.

¹ The Shore scale is commonly used as a measure of the physical hardness of polymers, composites and similar materials, see Section 3.2

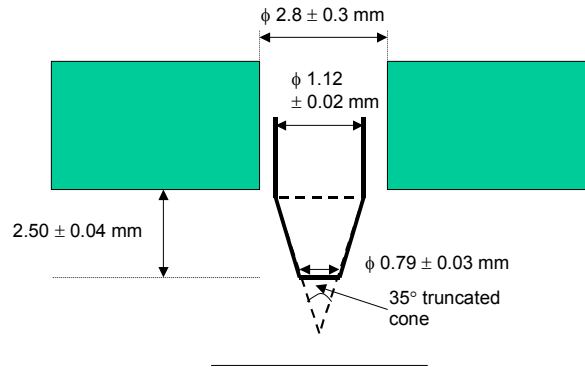

Figure 1: A schematic representation of the indenter used to measure hardness on the Shore A scale (redrawn from ASTM D 2240-04)

Hardness data are used for qualitative purposes since there is no simple relationship between these measurements and any fundamental properties of the material (ASTM D 2240-04). Measurements of the Shore hardness of the injection moulded plates were made using a Ray-Ran durometer (WS777). Pairs of samples approximately 50 mm by 50 mm and 2.6 mm thick, cut from a moulded plate, were stacked to form a composite thickness of approximately 7.8 mm to comply with the requirements of ASTM D 2240-04. No significant variation in hardness was discernable between different plates or across a plate. At least 6 measurements were made per sample at points more than 6 mm apart and away from any edge. Values of measured hardness are listed in Table 1.

The sample densities shown in Table 1 are based on measurements of plate dimensions and weight. Errors in the determination of density were minimised by using comparatively large samples of typical dimensions, 20 mm by 145 mm and 2.6 mm thick.

Table 1: Measured Shore hardness values and densities of a range of SEBS samples

Sample code	Tradename	Shore hardness (± 2)	Average thickness (mm)	Density (g/cm^3)	Sample colour
AAATF001	Multiflex G45A11	23A	2.67 ± 0.05	1.14	Black
AAATF002	Multiflex G75A	79A	2.68 ± 0.06	1.16	Black
AAATF003	Multiflex G45A21	43A	2.56 ± 0.06	1.19	Black
AAATF004	Multiflex G60A	62A	2.64 ± 0.08	1.12	Black
AAATF005	Multiflex G90A	93A	2.62 ± 0.07	1.05	White

4 DEVELOPMENT OF THE VOCABULARY FOR DESCRIBING THE TACTILE PROPERTIES

In any perceptual assessment of a material or object it is essential to identify a common vocabulary that has comparable meanings for people who may be of different sexes, ages and cultural backgrounds. This perceptual vocabulary will depend on the type of material that is being studied. Vocabulary elicitation and card sort analysis were used to establish appropriate terms for describing the tactile properties of the soft-touch rubber-like materials used in this investigation. The initial set of vocabulary words were elicited in individual sessions and informal focus groups in which participants touched a range of relevant samples of SEBS. The vocabulary items elicited in these sessions were then grouped using a card sort exercise conducted with a second group of participants. They were then analyzed with a cluster analysis to reduce the large initial number of words to the key dimensions and to establish whether these dimensions differ with gender, age or cultural background. (See Appendix 1 for further information about the methods used).

4.1 VOCABULARY ELICITATION STUDY

4.1.1 Participants

For the vocabulary elicitation study, a total of 105 participants were recruited. These were from eight different populations (see Table 2). A mix of men and women was sought for all groups.

Table 2: Participant characteristics for the vocabulary elicitation study

Group	Age range	Number of participants
Adults (English first language)	18 - 59	23
'Older' adults (English first language)	60+	10
'Younger' people	14 -16	30
English as a second language	Adults	8
Responses in Mandarin/Cantonese	Adults	10
Responses in Punjabi	Adults	8
Deaf since early in life	Adults	8
Blind since early in life	Adults	8

4.1.2 Procedure

Participants took part in this study individually, so they did not influence each other in their responses. Participants were presented with the eight samples in a random order and asked to feel them in any way they wished. Participants were then asked to produce any words that described the feel of the samples.

To ensure the samples were as free from dirt and grease as possible, various methods were used to clean the samples prior to handling. These included washing the samples with dishwashing liquid detergent, dusting them using a photographic air brush, and wiping them with different fabrics. The most effective method for removing dirt and grease was found to be wiping the surface of the sample with a 100% cotton cloth after

it had been washed in detergent and left to dry naturally. This procedure was adopted before any participants were allowed to handle the samples.

The participants were not blindfolded for this part of the investigation (although this was considered), but were asked to focus on their sense of touch and ignore the appearance, colour, form and size of the samples.

The Mandarin/Cantonese and Punjabi participants delivered their responses in their mother tongue. These were later translated into their truest English language equivalents by experts of that language. All other groups delivered their responses in English.

4.1.3 Results

102 unique words were produced to describe the feel of the samples. In total, 665 instances of words were produced (Appendix 2), with an average of six terms provided per participant. The frequency breakdown of terms in Appendix 2 also shows that some words were infrequently produced, e.g. 34 terms were only produced once.

The seven most frequently used words produced by all participants accounted for almost 50% of the total number of instances of words recorded (Table 3). The most frequently described word for the combined set of eight different samples was 'smooth'. This word was also the most, or joint most, frequently used word by six out of the eight participant groups. However, no Punjabi participants described a word in that language that translated to 'smooth' in English. The seven most frequently used words for all the 105 participants, are the same as the seven most frequently used words amongst the 23 English speaking/adult participants, although the rankings are different.

Table 3: Seven most frequently used words from the vocabulary elicitation study

Word	Number of participants
Smooth	62
Sticky	54
Hard	48
Rubbery	46
Soft	38
Gripping	32
Slippery	26

4.2 CARD SORTING STUDY

Having all the different words produced by the participants, even if one takes only the most commonly produced words, is not a particularly useful data set in itself. Some words may be synonyms or near synonyms of others. Therefore a method is required to reduce all the different individual words to meaningful clusters of words with the same or similar meanings. A card-sorting task, as described below, is a commonly used method for doing this. This yields the key terms underpinning all the different individual words produced to describe the feeling of the soft touch plastic samples.

4.2.1 Participants

Ten participants, 5 women and 5 men, took part in this study. All had English as their native language and were aged between 18 and 40 years.

4.2.2 Words Used

The words produced by the two adult groups that had English as their first language (18 – 59 year olds and those over 60 years) were used for this study. These 33 participants had produced 43 different words to describe the soft touch plastic samples (Appendix 3).

4.2.3 Procedure

Participants took part in this study individually. Each word was recorded on to an index card. The cards were presented to each participant in a random order to avoid any bias in the results due to card order. Each participant was then asked to group the cards into as many groups as they wished, based upon their judgement of their similarity on any dimensions. No group titles or characteristics were provided.

Participants were allowed to study the words and form and re-form the groups as much as they liked during the task. In this technique there are no ‘right’ patterns of grouping terms. As noted by Preece et al (2002) ‘[L]anguage is a form of social reality that is open to interpretation from different perspectives’.

4.2.4 Data Analysis

The groupings of words for each participant were noted and a data matrix of the number of times each word was grouped with each other word was produced. This matrix was analysed using a non-parametric cluster analysis (using the SPSS statistical package, www.spss.com, version 11.5.0). The output is a series of clusters that are categorised into ‘...tighter and tighter clusters of maximum similarity, and separations into disparate clusters with maximum dissimilarity’ (Snodgrass et al, 1985). Thus cluster analysis reveals the average groupings of elements (in this case, groupings of words) across a number of participants and shows the strength of these groupings.

4.2.5 Results

The number of groups produced per participant ranged from five to nine, with an average of seven.

The cluster analysis also produced seven distinct clusters (see the dendrogram in Appendix 4). An examination of the words in each cluster lead to a cluster title or key word and a description of the cluster, these are given in Table 4, below.

Table 4: Results of the cluster analysis for the card sorting study

Cluster Title	Example words in the cluster	Comments and associations
Feminine	Silky Soft Slimy Slippery Shiny Smooth Synthetic	Words associated with the feminine gender type and direct sensational perception.
Pleasant	Comfortable Comforting Erotic Sensual Sweetie Giving	Words associated with a general psychological and emotional reaction to the material
Elastic	Elastic Flexible Pliable Rubbery	Words that describe elasticity properties, reflecting the flexibility of the material.
Masculine (hard)	Functional Gripping Cold Dry Blu-tak Heavy Light Firm Hard Matt	Words associated with the masculine gender type and are material related. This cluster could also be further divided into two separate clusters; <ul style="list-style-type: none"> • <i>Functionality</i>: Functional, Gripping, Cold, Dry, Blu-tak • <i>Solidity</i>: Heavy, Light, Firm, Hard, Matt
Uncomfortable	Sticky Tacky Unpleasant Yucky Warm Wet	Words that are generally associated with negative emotions.
Robust	Resistant Robust Masterful Thick Unyielding	Words that have a strong association with the concept of strength.
Malleable	Spongy Squashy Squeezable Stretchy	Words that are associated with the compliance of the materials

Very close associations between specific words in a cluster were also displayed in the dendrogram (for example, *spongy* and *squashy* or *elastic* and *flexible*).

These seven key cluster groupings describe the basic dimensions of way people conceptualize their perception of the soft touch plastics. These clusters might well be applicable to the perception of other materials, but this would require further empirical work to establish. Each of these cluster dimensions could be further investigated to understand how the physical properties of materials relate to their perception. For this investigation, two terms from within the first cluster were chosen: smoothness and softness. These two terms were chosen for a number of reasons. Firstly, the first cluster, feminine, appears to describe the basic perceptual sensations related to simple touching of surfaces. Secondly, the terms chosen also appeared in the most frequently used words from the vocabulary elicitation study (smooth was the most frequently used word; soft was the fifth most frequent word and hard, the antonym/bipolar pair, was the third most frequent). Thirdly, these two terms relate to different types of touching processes. Smoothness relates to a horizontal touching processes – stroking or sliding one’s fingers along the surface of an object², whereas softness relates to a vertical touching processes – pushing or probing an object.

5 DETERMINATION OF PSYCHOPHYSICAL RELATIONSHIPS

Relating the psychological perception of properties of objects with the physical characteristics of the object is known as psychophysics. This was one of the first areas of research in psychology and has been studied since the 1860s (see Appendix 1 for further information). A number of different psychophysical methods have been developed, each suitable for different situations. Of these, magnitude estimation was chosen as the most appropriate – a situation in which we have some precise measurements of the physical softness of the materials of interest, and a number of psychological dimensions related to the perception of the materials (determined by the word elicitation study), but little or no information about the relationship between the physical characteristics and the psychological perceptions.

Two words from the key cluster derived from the cluster analysis were used for the psychological terms in the psychophysics: softness and smoothness. Both these terms were also in the seven most frequently used words to describe the samples.

PSYCHOPHYSICAL ASSESSMENT OF SOFTNESS

Most everyday objects that we touch can be simply classified into three categories: flat surfaces, curved surfaces and cylindrical surfaces that may invoke different sensory responses depending on their detailed geometry. Significantly increasing the diameter of a small cylindrical object such as a pencil will result in different populations and combinations of cutaneous and kinaesthetic receptors being utilised.

Two aspects of the physical presentation of the samples were investigated to assess their impact on the psychological perception of the softness of the material:

- Curvature of sample – samples were presented either as a flat surface, a curved surface or a cylindrical surface. The rationale for the curved and cylindrical presentations was that these presentations mimic consumer surfaces that

² Smoothness is defined here as the perception of one aspect of the surface by an individual

typically use soft plastics such as car dashboards or door panels (curved presentation) and small consumer items such as toothbrushes, pen and tools (cylindrical presentation). (See Figures 2, 3 and 4 for illustrations of the different presentations of the samples).

- Thickness of sample – the relationship between the thickness of the sample of soft plastic and the perception of its softness is clearly important for the manufacture of items with soft plastic surfaces. This factor could not be explored in detail in the current study, but two thicknesses of sample were used: 2.6 mm and 3.9 mm.

METHOD

5.1 PARTICIPANTS

Four men and four women participants' aged between 18 and 40 took part in the study. They were from different cultural backgrounds: Italian; English; Greek; Indian; Polish. For this part of the investigation the participants were blindfolded to remove any influences from colour differences between the samples or sample recognition.

5.2 MATERIALS

The stimuli for each type of presentation consisted of 5 TPE samples each with a different level of physical compliance (Shore A hardness) as described in Table 1. Samples were attached using an adhesive to both cylindrical and curved surfaces to invoke different combinations of cutaneous and kinesthetic responses. The cylindrical mandrel had an outer diameter of approximately 47 mm. The radius of the half-cylinder used as a curved surface was 38 mm. Both thin and thick sheets of the TPEs detailed in Table 1 were used in this investigation. Care was taken to ensure that the samples were not stretched during the mounting procedure and that the free edges were securely attached.

5.3 PROCEDURE

The magnitude estimation procedure was used. An active touch paradigm was used, whereby the participant moved their finger(s) across/into the sample, so that both cutaneous and kinesthetic information was available to the participant.

A pilot study was first carried out to ensure instructions were clear and the touch procedures could be reliably reproduced. The way the participant interacted with the sample set was determined by the characteristics of the set and the psychological dimensions under investigation.

For the perception of softness, the following interaction procedures were used:

- For flat samples, the participants were asked to press the index finger of their dominant hand into the sample in a downward fashion (Figure 2). The samples were placed on the same rigid flat wooden table for all trials, with all participants, to create an equal level of resistance.



Figure 2: Procedure to assess the softness of a flat sample



Figure 3: Procedure to assess the softness of a cylindrical sample

- For the cylindrical sample set, participants were asked to grasp the sample with their dominant hand and apply moderate force with their fingers and thumb (Figure 3).
- For the curved sample set the participants second finger and thumb of their dominant hand straddled the sample applying a downward pressure in conjunction with the index finger (Figure 4).



Figure 4: Procedure to assess the softness of a curved sample



Figure 5: Procedure to assess the smoothness of a flat sample

Participants were asked to stroke the sample using the index and adjacent two fingers of their dominant hand to assess the smoothness of flat samples as shown in Figure 5.

The participants were encouraged to undertake the tests in a repeatable fashion i.e. maintaining some degree of constancy in the:

- Posture of contacting finger(s) and joints activated
- Relative velocity which finger(s) approach the stimuli
- Applied contact force

This helped to ensure that the participants' performance was maintained and did not cause adverse influence upon the results (Srinivasan and LaMotte, 1995): any significant changes in test methodology were easily observable by the tester.

Participants were first presented with a sample that had Shore Hardness of 60A. This sample acted as a point of reference, the modulus sample, and was assigned a value of 10 by the evaluator. The participants were then presented with each of the other samples

in the set and asked to assign an intensity value to each relative to the modulus sample. For example, if a participant felt a given sample was twice as soft as the modulus then they would assign a softness value of 5, if on the other hand they thought it was half as soft they would assign it a value of 20. The participants were allowed to feel the modulus sample within any given set of samples at any point during the evaluation process.

Participants were encouraged to give their first reaction to the sample. Limiting the number of amount of times that the evaluators touched each sample to around three minimized loss of fingertip sensitivity and overtiring. Finger bowls of water were provided to help participants revive their fingers and remove any residue should it be necessary. Practice and fatigue effects, were eliminated by presenting the samples in a random order.

Each evaluation took approximately 20 minutes. After the evaluation was completed, participants were debriefed as to the purpose of the study and in particular the physical characteristics of the different samples they had touched.

5.4 RESULTS

The relationship between the physical hardness of the samples (as measured on the Shore hardness scale) and the perception of softness was analysed using an Analysis of Variance (ANOVA). The raw magnitude estimates were the dependent variable. The independent variables consisted of:

- Surface type (4 levels: thick flat, thin flat, thick curved and thick cylindrical) (within participant measure)
- Physical hardness (5 levels: Shore A hardness, see Table 1) (within participant measure)
- Run (2 levels: each sample was presented twice) (within participant measure)
- Sex of participant (between participants measure).

The ANOVA showed that the only significant main effect was for physical hardness, $F = 41.09$, $df = 4,3$, $p < 0.01$. This main effect is illustrated in Figure 6, below. There was a highly significant linear relationship between physical hardness and perception of softness, $F = 78.76$, $df = 1,3$, $p < 0.01$ (as indicated by the linear trend line in Figure 6) and a significant quadratic relationship $F = 6.68$, $df = 1,3$, $p < 0.05$. None of the interactions were significant.

These findings reveal a very clear relationship between the perception of softness and the physical hardness of the samples that is not affected by other factors investigated such as the thickness of the sample, the shape of the surface presented, or the sex of the participant.

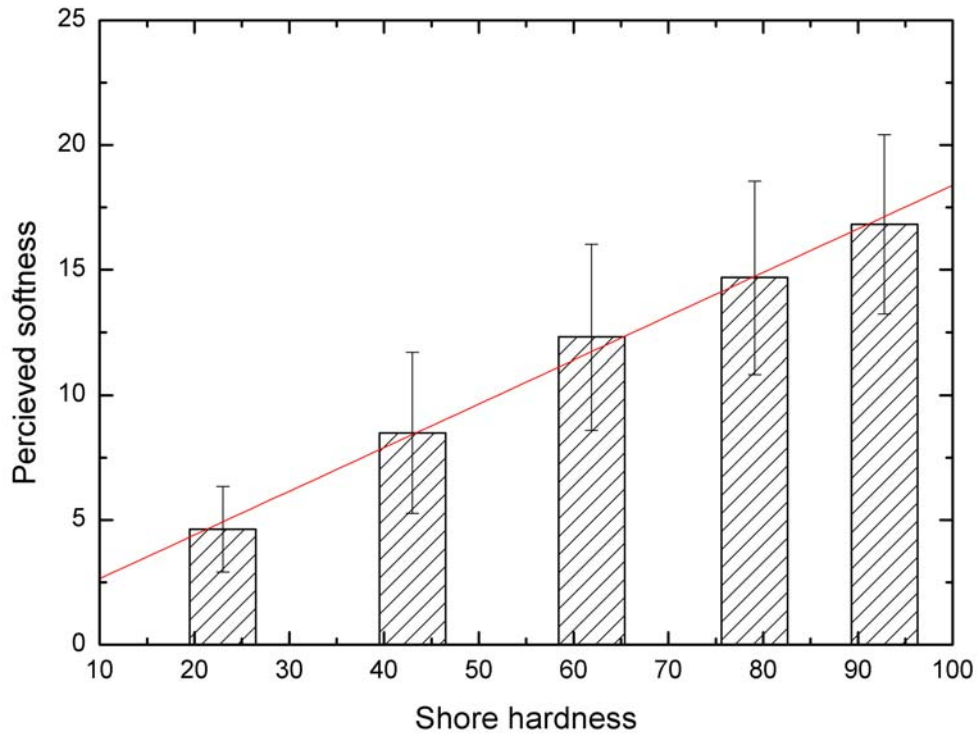

Figure 6: Relationship between physical hardness (Shore A hardness) and perceived softness (Raw Magnitude Estimate, ME) for all sample types

The relationship between the physical hardness and the perception of smoothness was also analysed using Analysis of Variance (ANOVA) with the raw magnitude estimates of perceived smoothness as the dependent variable and the same independent variables as in the previous analysis.

The ANOVA showed that although there was no significant main effect for physical hardness, $F = 1.88$, $df = 4,4$, $p = 0.15$. The quadratic and higher order relationships were not significant.

A simple power law relationship, following that described by Steven's (Stevens, 1975), i.e.

$$ME = a.SI^b \quad (1)$$

links the estimated magnitude of a stimulus, ME with its physical magnitude, SI. The parameters a and b refer to a scaling coefficient and an exponent respectively. The exponent for the relationship shown in figure 6 is 0.9, a value that compares well with published data for squeezing rubber (0.8) and palm pressure – applying a static load to the skin (1.1) (Stevens, 1975). A Stevens' plot of these data is shown in Figure 7. From this relationship it is possible to predict the 'feel' of a material from a known Shore hardness, a fact that will be exploited in a subsequent analysis of the effects of using rubber-like materials as overmouldings where the actual Shore hardness is substantially different to that derived from ASTM D-2240 due to the edge effects.

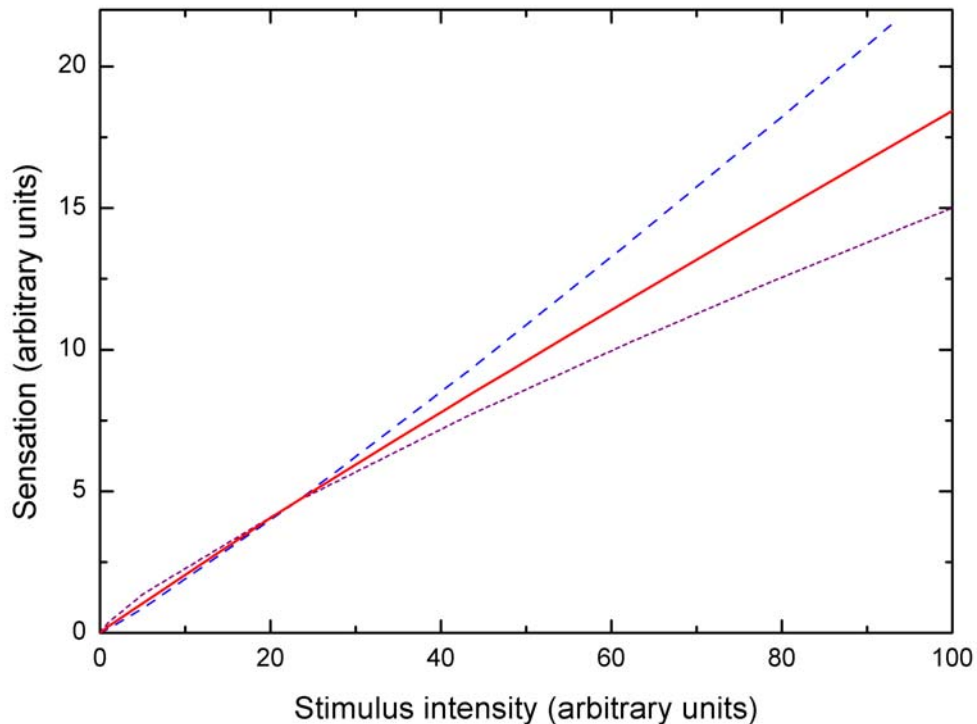

Figure 7: Power law exponent for perceived softness and smoothness of soft plastics in relation to other touch exponents (----- this investigation, - - - - palm pressure, tactile hardness).

6. DISCUSSION AND CONCLUSIONS

This set of studies has provided some interesting new data on the perception of the soft touch thermoplastic elastomers. In this section we summarize the main findings and discuss their implications.

The vocabulary elicitation study was undertaken to investigate the words used to describe the perceptual characteristics of the soft touch plastics yielded over 100 distinct words from 105 participants. However 7 words accounted for almost 50% of the words produced. The three most commonly produced words were “smooth”, “sticky” and “hard” (with its opposite “soft” being the fifth most common word). Some interesting differences emerged between the different groups who participated in the vocabulary elicitation study. The words elicited from the younger people (14 – 16 year olds) showed some differences from the two adult groups, although there were no differences between the adults (18 – 59 years) and the older adults (60 years and over). This needs further investigation, as the number of participants in each age group was relatively small, but tentatively suggests that the vocabulary for these perceptual aspects matures relatively late.

There were also suggestions of very interesting cultural differences. Again, the number of participants from each non-English speaking cultural group was small, but the fact that no Punjabi participant produced a word that corresponded to the English term “smooth” is very striking. Statistically one would expect about half the participants to produce this word. So, cultural differences in the vocabulary of the perception of soft plastics definitely require further investigation.

The card sorting exercise and subsequent cluster analysis showed that there were clear groupings of the words with seven distinct clusters produced:

- “feminine” which describes the basic perceptual sensations related to simple touching of surfaces.
- “pleasant”, describes the psychological connotations and emotional reactions to the plastics materials.
- “elastic”, describes some of the basic physical characteristics of plastics.
- “masculine” which includes words associated with masculinity that can be further subdivided into two components concerned with functionality and solidity of the material.
- “uncomfortable”, words that relate to discomfort such as yucky and sticky.
- “Robust”, words that are associated with the concept of strength.
- “malleable”, words that are associated with materials compliance

Two dimensions were chosen from the vocabulary study and our analysis of the soft plastics to investigate in the psychophysical study: softness and smoothness. Both dimensions were from the first, strongest cluster of words which emerged from the vocabulary study. Smoothness was chosen as it was the most frequently used word to describe the feel of the soft plastics (although it was not expected there would be a strong relationship with Shore A hardness values). Softness was chosen, partly because both components of the soft/hard antonym pair appeared in the most frequent words used. But secondly, softness seemed to be the psychological dimension with most obvious relationship to Shore A hardness values. Finally, these two dimensions were chosen as softness relates to a vertical compression of a surface by the finger and smoothness relates to a horizontal sweep across a surface.

A very strong relationship was found between the perception of softness of a surface and the physical hardness of the samples, as had been predicted. However, it was surprising that this relationship was not affected by other factors investigated such as the thickness of the sample (for the two thicknesses used in the study), the shape of the surface presented (for those values explored within this research), or the sex of the participant. So the perception of the softness of a plastic surface is very robust in relation to a number of presentation variables. However, it should be remembered that only two thicknesses of plastic coating of a surface were investigated, so the relationship between perceived softness and plastic thickness clearly warrants a full investigation of its own. However, we would recommend that this could be conducted only with flat samples and the results would be generalisable to curved surfaces, given the robust findings on surface shape from this study.

On the other hand, as expected, no significant relationship was found between the perception of the smoothness of a surface and the physical hardness of the samples, nor any significant interactions with the other variables such as surface shape. This may be because frictional forces between the finger tips and the sample being investigated are likely to play an important role in our perception of smoothness. The magnitude of these frictional forces depends on a complex relationship between the adhesive forces that develop between the skin and the materials surface and how much the material and finger deform during stroking. The amount of deformation that fingers undergo during stroking is very directionally dependent: much less movement occurs during ‘pushing’ than in sliding from side to side for a given finger orientation. The amount of deformation that the material is subject to will depend on the contact force and how stiff it compared to a finger: glass will suffer no deformation in contrast to a very soft

rubber. When we compare the results on the relationship between perceived softness and physical hardness with previous findings, we find that they fit well with similar perceptual judgements.

This research has shown that a rich and interesting vocabulary is used to describe the characteristics of soft plastics. Further research is needed to completely understand this vocabulary and so investigate how far it generalises to similar materials. In addition, there were suggestions of interesting cultural differences in the vocabulary used to describe these plastics. Again, further research is needed to confirm these possible differences.

The research has shown that there is a robust relationship between the perception of softness of thermoplastic elastomers plastics and shore hardness, a relationship not affected by the manner of presentation of the testpiece. This makes life somewhat simpler for people wishing to use the results of this research to develop soft plastic products of optimal softness for consumers – further investigations probably do not need to take into consideration the shaping of the soft plastic material.

7 ACKNOWLEDGEMENTS

The authors would like to thank Crispin Allen of the National Physical Laboratory for his help in preparing the test specimens. This work was funded by the United Kingdom Department of Trade and Industry as part of its programme of research on Materials for Processing and Performance (Project MPP 7.7: Soft Touch Metrology Of Soft Touch Polymers And Elastomers).

8 REFERENCES

- Allard, F. (2004) Lecture 4: Direct scaling. [Online]. Available: <http://www.ahs.uwaterloo.ca/~kin356/lecture4.pdf> [12 July 2004]
- ASTM D2240-04 Standard Test Method for Rubber Property—Durometer Hardness
- Bicchi, A., De Rossi, D. and Sciling. P. (2000). Haptic discrimination of softness in teleoperation: The role of the contact area spread rate. *IEEE Transactions on Robotics and Automation*, 16(5), 496-504.
- Colwill, M. J., Warren, S., Workman, C., Jones, K., Robins, T., Rait, J., De Pennington, A., and Childs, T. (2003). Affective Design (Kansei Engineering) in Japan. Leeds: University of Leeds Media Services.
- Craig, J.C. and Rollman, G.B. (1999). Somesthesia. *Annual Review of Psychology*, 50, 305-331.
- Dex Plastomers (2000). Exact® concept for soft touch blow moulded bottles. Available: www.dsm.com/newsarchive/2000/~en/t_soft_touch_en.htm [5 November 2004]
- Goldstein, E. B. (1996). *Sensation and perception*. 4th Edition. Pacific Grove, CA.: Brooks/Cole.

Jansson, G., Billberger, K., Petrie, H., Colwell, C., Kornbrot, D., Fanger, J., Konig, H., Hardwick, A. and Furner, S. (1999). Haptic virtual environments for blind people: Exploratory experiments with two devices. *The International Journal of Virtual Reality*, 4(1), 10-20.

Johansson, R. S. and Westling, G. (1990). Tactile Afferent Signals in Control of Precision Grip. In M. Jeannerod (Ed.), *Attention and Performance*. Mahwah, NJ.: Lawrence Erlbaum and Associates.

Katz, D. (1925/1989). Der aufbau der tastwelt (The World of Touch). Translated by L. Krueger (1989). Mahwah, NJ.: Lawrence Erlbaum and Associates.

Klatzky, R. L. and Lederman, S. J. (2002). Touch. In A.F. Healy and R.W. Proctor (Eds.). *Experimental Psychology. Vol 4 of Handbook of Psychology*. New York. John Wiley and Sons.

LaMotte, R. H. (2000). Softness discrimination with a tool. *The Journal of Neurophysiology*. **83(4)**, 1777-1786

Lederman, S. J. (1974). Tactile roughness of grooved surfaces: The touching process and effects of micro- and macro-surface Structure. *Perception and Psychophysics*, **16**, 385-395.

Leeds University. (2004). What aspects of a surface's finish make it pleasant or unpleasant? Affective Engineering. Available: <http://www.mech-eng.leeds.ac.uk/res-group/dandm/surfacefinish.html> [12 July 2004]

MIT Media Laboratory . (2004). Research on Affective Pattern Recognition and Modelling. Affective Computing. Available: http://affect.media.mit.edu/AC_research/recognizing.html [15 July 2004]

Okamura. A. (2003). Haptics for Virtual Reality; Lecture 2 [Online]. Available: <http://pegasus.me.jhu.edu/~allisono/courses/530.651/lectures/lecture02.pdf> [21 September 2004]

Petrie, H., Penn, P. R., Kornbrot, D., Furner, S. and Hardwick. A. (2000). Haptic virtual environments for blind people: Further explorations with the Phantom device. *Proceedings of the 3rd International Conference on Disability: Virtual Reality and Associated Technologies*. Alghero, Sardinia, Italy.

Pont, S.C, Kappers, A.M.L, and Koenderink. J.J. (1999). Similar mechanics underlie curvature comparison by static and dynamic touch. *Perception and Psychophysics*, **61**, 874-894

Preece, J, Rogers, Y, and Sharp, H. (2002). *Interaction Design: Beyond Human – Computer Interaction*. New York: John Wiley & Sons.

Presence Research. (2004). Psychophysical Measures. Available: <http://www.presence-research.org/Psychophysical.html> [10 July 2004]

Snodgrass, J. G., Levy-Berger, G. and Haydon, M. (1985). *Human experimental psychology*. Oxford. Oxford University Press.

Srinivasan, A, and LaMotte, R. H. (1995). Tactual discrimination of softness. *Journal of Neurophysiology*. **73(1)**, 88-101.

Srinivasan, A., and LaMotte, R. H. (1996). Tactual discrimination of softness: Abilities and mechanisms. In O. Frazen, R. Johansson and L. Terenius (Eds.), *Information Processing in the Somatosensory System*. Basel: Birkhauser Verlag.

Stevens, J.C. and Patterson, M. Q. (1995). Dimensions of spatial acuity in the touch sense: Changes over a lifespan. *Somatosensory and Motor Research*, **12**, 29-47.

Stevens, J.C, and Choo, K. K. (1996). Spatial acuity of the body surface over the lifespan. *Somatosensory and Motor Research*, **13**, 153-166.

Stevens, S. S. (1975). *Psychophysics: Introduction to its perceptual, neural and social prospects*. New York: John Wiley & Sons.

Tomlins, P.E., Rides, M., Dawson, A., Gee, M., Hobbs, C., Allen, C., Dean, G.D., Ganiah, A., Calver, A. and Darling, R. (In preparation). On the physical characterisation of soft touch polymers, National Physical Laboratory Report.

Wilson, F.R. (1998). *The hand*. New York: Vintage Books.

APPENDIX 1 – A BRIEF INTRODUCTION TO THE PSYCHOLOGY OF TOUCH

A1.1 INTRODUCTION

The sense of touch is a combination of stimulations derived from direct contact with an objects surface, and a more general sensing of movement. Touch, as a sense has received far less attention than vision or hearing as a topic of psychological research, but it is one that should not be ignored. Human factors research into this topic influences a wide range of industrial designs; from automotive interior components such as steering wheels and gear leavers, watches and computer hardware (Colwill et al., 2003). Research into the development of virtual environments for blind people has also been enhanced by studies into the sense of touch (Petrie et al, 2000).

Studies into the psychology of touch

Studies to measure differences in the compliance of surfaces have been conducted with both human and non-human subjects. Most research since the 1920s (Katz, 1925) focuses on the perceived roughness of surfaces. However, work in recent years has been directed at establishing the perceived compliance, i.e. compressibility, of materials by human touch, most notably by Srinivasan and LaMotte (1995).

Studies into the psychology of touch have to-date applied one of the many established methodologies emerging from the psychophysics discipline. However, research into affective computing conducted at the MIT Media Lab has highlighted alternative methods to analyse the behavioural and physiological expressions of emotion.

‘We are interested in emotional expression through verbal as well as non-verbal means, not just how something is said, but how word choice might reveal an underlying affective state’ (MIT Media Laboratory, 2004)

This concept has been developed further and exploited through the association of adjectival terminology elicitation to translate consumer feelings into design elements (Colwill et al., 2003)

A1.2 THE HAPTIC SYSTEM

The ability of humans to detect the tactile sensation of an object is related to our haptic senses which include the cutaneous or tactile receptors located within the skin which inspire tactile feedback (Figure A1), and kinesthetic receptors which receive sensory inputs from the body’s muscle tendons and joints, thus inspiring force feedback (Figure A2). The human hand and more specifically the fingers are particularly effective at processing spatial information via the skin due to a high density of receptors (Klatzky and Lederman, 2002). Furthermore, neurophysical evidence has identified that the ways in which people grasp, grip and manipulate objects is related to the cutaneous mechanoreceptors present in hairless skin (Johansson & Westling, 1990).

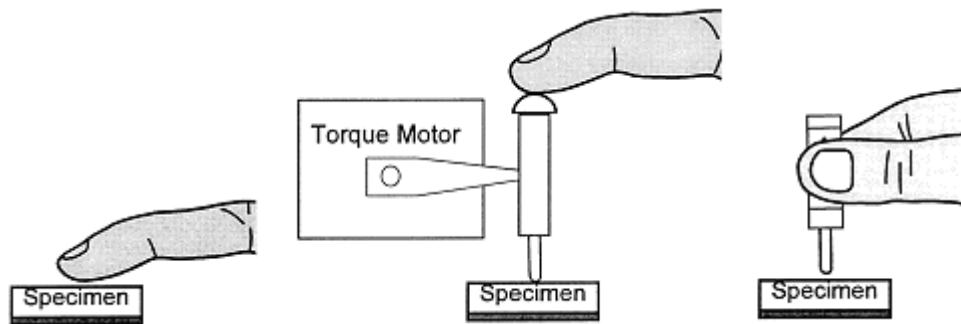

Figure A1: Cutaneous receptors inspire tactile feedback (LaMotte, 2000) Reprinted with permission

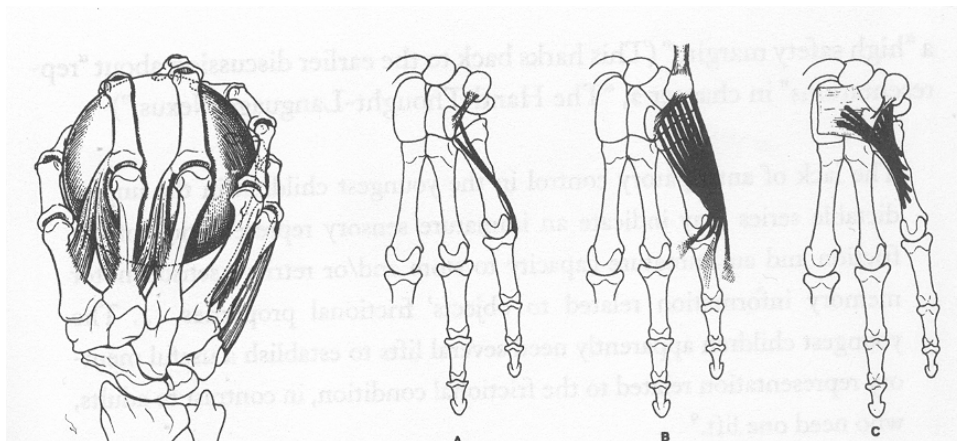

Figure A2: Kinesthetic receptors inspire force feedback (Wilson, 1998) Reprinted with permission

It is widely acknowledged that with age our cutaneous sensitivity decreases due to a loss in the number or sensitivity of receptors. Stevens and Patterson (1995) proposed that an increase in the threshold of the cutaneous mechanoreceptors is approximately 1% per year, between the ages of 20 and 80. More recently Stevens and Choo (1996) evaluated the effects of age upon the threshold of 13 different sites of the body. Their results showed that hands and feet, due to reduced circulation, are the most effected. Thus, affecting our ability to grasp and manipulate objects.

The properties of an object perceived by the haptic system can be separated into two categories; geometric properties concerned with the size and shape of an object and material properties with, for example, texture, compliance and temperature of an object.

A1.2.1 Geometric properties.

The size and shape of an object determines which aspect of the haptic senses we require to distinguish its geometry. For example, a small object such as a pea has a small radius of curvature, therefore the whole surface can be covered by one finger, thus only requiring the use of cutaneous receptors to establish its shape. Alternatively, more than one finger will be required to analyse the size and shape of a larger object with a small radius of curvature, as a single finger ‘...may not make it discriminable from a flat surface’ (Klatzky and Lederman, 2002). Several fingers provide kinaesthetic

information in addition to that generated by several sets of cutaneous receptors, information that is needed to analyse the form of large curved surfaces.

A1.2.2 Material properties.

Research has shown that surface texture (smoothness) is perceived by running a finger along the surface of an object, identifying the spacing between elements (Klatzky and Lederman, 2002). People generally regard an object, as having a perceivable texture when it has elements that are spaced not more than 3 mm – 4 mm apart. Beyond this limit the object is regarded as being smooth with ‘punctured irregularities’. Additionally, any increase in the height or peak of an element, also leads to a decrease in the perceived texture of the surface. It appears that the kinesthetic receptors have little impact on the perception and triggering of surface texture, which is detected through skin deformation and triggering of cutaneous receptors in the fingertip. Increasing the force of the finger upon the object also increases the perceived magnitude of the smoothness, whereas the speed of motion between finger and surface has very limited effect (Lederman. 1974).

The hardness of an object is subject to its compliance, as perceived by our haptic senses. Bicchi et al (2000) state:

‘It has been firmly established in psychophysical literature that the ability of discriminating softness by touch is intimately related to both kinesthetic and cutaneous tactile information in humans.’

In contrast to the above statement, during Srinivasan and LaMotte’s (1995) work on the tactual discrimination of softness, they conducted active touch experiments in which they anaesthetised the participants’ fingers. Thus, the participant was only able to distinguish between soft and hard specimens by using their kinesthetic system. The result was that participants could not even identify the difference between the two extreme ends of the spectrum without the use of their cutaneous system. In contrast, when the experiment was reversed, whereby the participants only had cutaneous information made available to them via a passive touch experiment ‘...the subjects performed at approximately the same level as under non-anaesthetised active touch... Thus tactile information alone is sufficient to discriminate the softness of objects.’

Srinivasan and LaMotte (1996) proposed two separate categories that group objects according to their compliance, and the subsequent proportion of cutaneous versus kinaesthetic receptors required in discriminating them.

- *Deformable objects whose surface is also deformable* e.g. rubber or fruit. Kinesthetic receptors often have little bearing on the judgement of conformance of these objects, cutaneous feedback alone can discriminate the hardness.
- *Deformable objects whose surfaces are rigid* e.g. piano or typewriter keys. Kinesthetic feedback is required in this classification for the object, though rigid on the surface, is compliant when pressed.

A1.2.3 Psychophysics

Psychophysical investigations attempt to link our psychological reactions with the physical measurable properties and are used to establish quantifiable relationships between physical stimuli and perception based on uni-dimensional scaling (magnitude estimation) or cluster analysis (Snodgrass et al, 1985).

A1.2.4 Established methodologies

The principal route to deriving the relationship between perceived stimulus intensity and one that can be physically measured has not changed significantly since Fechner's pioneering work in the 1860's (Snodgrass et al, 1985). For example, a subject assigns a subjective rating to a stimulus that can be reliably measured. As with all subjective methods, psychophysical measures are susceptible to bias by either the evaluator or the participant or both.

What these methods will measure is heavily dependent on the evaluator's instructions, and on the participant's own interpretation of what they should rate. (Presence-Research, 2004)

The classical methodologies described by Fechner are:

Method of Limit. Regular increases or decreases in intensity. A problem exists in that users may have a tendency to keep responding 'yes' in a descending series after the threshold has been reached (error of habituation).

Method of Constant Stimuli. Levels of intensity are repeatedly presented in a random order, the intensity rating that is detected on 50% of trials is awarded the rating of absolute threshold.

Method of Adjustment. Once the stimulus intensity is detectable then an absolute threshold is awarded. Problems exist in the differences in individual perception of stimuli of particular intensities.

Weber introduced another methodology to measure the threshold intensity (Snodgrass et al, 1985)

Signal Detection Theory (SDT). An approach that aims to rectify the susceptibility of Fechner's methods above to psychological factors (response bias) that may lead to participants believing that they detect a stimulus intensity when they actually do not. There is no *threshold of awareness* as such, but rather a continuum of sensations. According to this theory, the observer will have to establish some criterion for deciding in favour of or against the presence of an external signal. Such a criterion is termed a *response threshold*. It differs from a *stimulus threshold* in that is an arbitrary point along the sensation continuum rather than one fixed by the observer's sensory system. The observer is as aware of stimuli below the response criterion as of those above it. Because it is an arbitrarily defined point, the subject can easily shift it if the situation demands it.

Magnitude estimation

Magnitude estimation relates the magnitude of physical stimuli to a given number assigned to them (how much of a given sensation a person is experiencing). In magnitude estimation experiments participants are presented with a medium intensity stimulus (the modular) that has an assigned number i.e. 10. The participants are then presented with a series of stimuli that include, and differ, from the mid-range modular intensity, and are asked to assign each of the samples a number relative to the modular. Thus the results are not about absolute accuracy of judgments, but about the relative relationships between judgments of stimuli of different intensities.

The numerical mean of the subjective judgments can then be plotted against the intensity of the stimulus to establish if doubling the actual intensity does lead to a doubling of the perceived intensity. Stevens displayed that by applying this methodology this is not always the case. For example, Figure A3 displays the perceived magnitude and stimulus intensity for electric shock, line length and brightness. It is apparent that doubling the intensity of light only has a small change on the perceived brightness (response compression), thus it is necessary to increase intensity by up to 9 times to achieve the psychological judgment of double brightness (Goldstein, 1996). In contrast, the doubling of an electric charge is perceived as being extremely more intense (response expansion), and line length is linear.

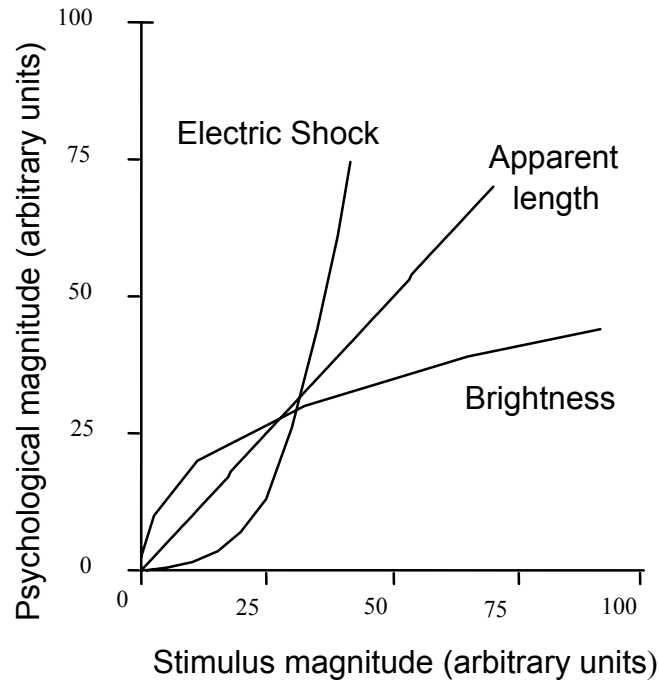

Figure A3: The psychophysical functions for electric shock, apparent length, and brightness (adapted from Stevens, 1975)

The psychological theory underpinning magnitude estimation therefore states that the relationship between perceived psychological intensity, ME is related to the actual physical intensity, SI raised to the power, b, as demonstrated by Stevens power law (Stevens, 1975).

$$ME = a.SI^b \quad (A1)$$

The exponent, b in equation A1 describes the relationship between the intensity of a stimulus and our perception of its magnitude (Jansson et al, 1999). A value below 1.0 means that the physical intensity rises more slowly than physical intensity; values greater than 1.0 mean that the physical intensity rises faster than the increases in physical intensity. Hence, equal ratios of physical intensity and sensation produce a measure of 1.0.

Table A1: Representative exponents of the power functions relating subjective magnitude to stimulus magnitude

Continuum	Measured exponent	Stimulus condition
Visual length	1.0	Projected line
Brightness	0.33	5° target in dark
Electric shock	3.5	Current through fingers
Tactual roughness	1.5	Rubbing emery cloths
Tactual hardness	0.8	Squeezing rubber

Magnitude estimation has received criticism by ‘reflecting more what subjects know about the properties of numbers than the strength of sensations’ (Allard, 2004). In response to this, Stevens developed *cross-modality matching* where by number measures are replaced with non-verbal responses. For example, varying the pressure when squeezing the hand of the evaluator to indicate the tone of a noise, or drawing of a line where the length represents the brightness

Controlled conditions in which participants are asked to perform experiments via *active* or *passive* touch are often applied to magnitude estimation experiments. Active touch represents the most common way humans interact with different materials in real life, enabling kinesthetic and cutaneous feedback. In contrast, passive touch involves the stimuli being presented to the participant, thus only their cutaneous receptors provide feedback. Most research to date has been concentrated around passive touch (Craig and Rollman, 1999).

APPENDIX 2: FREQUENCY OF TERMS

Terms	Eng/Adult	Eng/Old	Young people	English second language	Mandarin / Cantonese	Punjabi	Deaf	Blind	Total
smooth	13	6	25	3	5		6	4	62
sticky	10	5	22	4	1	7	2	3	54
hard	11	2	18	3	5	3	2	4	48
rubbery	12	3	19	3	2		4	3	46
soft	9	1	15	4	3	1	3	2	38
gripping	7	5	13	1		1	3	2	32
slippery	9	1	6	1	3	3	3		26
shiny	2	2	16	1				1	22
cold	6		13	1					21
stretchy	1		15	1			1		18
flexible	4		8				1	1	16
firm	2	4	5	1			1	1	14
rough	1		9		1	1	1	1	13
elastic	2		7	3					12
warm	1		10	1					12
spongy	6		3		1	1			11
thick	2		7					1	10
matt	1		7						8
tough	2		5				1		8
light		2	4	1					7
plastic	1		3		3				7
squidgy	1		6						7
strong			7						7
springy			5						6
clammy	1		3		1				5
dry	1		4						5
heavy		1	4						5
stiff			5						5
sweaty	1		4						5
tacky	3	1	1						5
taut			5						5
wet	1		2	1	1				5
bouncy	1		1	1			1		4
cool			4						4
friction	1		1	1				1	4
greasy	2		1				1		4
non-slip						1	3		4
pliable	4								4
silky	1		3						4
thin			3					1	4
clean			1			1		1	3
solid			3						3
squeezable		1	2						3
clear			1					1	2
comfortable	1	1							2
dirty			2						2

durable			1		1				2
erotic	1		1						2
gliding			2						2
hot			2						2
leather substitute					1			1	2
oily				1	1				2
protective				1			1		2
resistant	1			1					2
rigid	1						1		2
robust	1		1						2
sensual	1		1						2
slimy	1		1						2
squashy	1		1						2
squishy			2						2
tactile			1						2
unpleasant	1		2						2
waterproof			1		2				2
absorbing				1					1
bendy									1
blu-tak	1		1						1
chewy				1					1
comforting	1								1
conduce				1					1
cuddly			1						1
dark			1						1
dull			1						1
dusty			1						1
easy						1			1
expanding							1		1
functional	1								1
glossy			1						1
giving	1								1
insulated (north pole, Iceland)					1				1
lasting					1				1
masterful	1								1
non-compressible								1	1
pinchable			1						1
plasticine						1			1
polished	1								1
porous								1	1
PVC					1				1
shield				1					1
sleek			1						1
slidey	1								1
synthetic		1							1
tense			1						1

unchangeable			1						1
unwashed							1		1
unyielding	1								1
varnished	1								1
vile			1						1
vinyl	1								1
waxy			1						1
yucky	1								1

APPENDIX 3: UNIQUE TERMS FOR CARD SORT EXERCISE

Terms	Instances
blu-tak	1
bouncy	1
clammy	1
cold	6
comfortable	2
comforting	1
dry	1
elastic	2
erotic	1
firm	6
flexible	4
friction	1
functional	1
giving	1
greasy	2
gripping	12
hard	13
heavy	1
light	2
masterful	1
mat	1
plastic	2
pliable	4
polished	1
resistant	1
rigid	1
robust	1
rough	1
rubbery	16
sensual	1
shiny	4
silky	1
slidey	1
slimy	1
slippery	10
smooth	19
soft	10
spongy	6
squashy	1
squeezable	1
squidgy	1
squishy	1
sticky	16
stretchy	1
sweetie	1
synthetic	1
tacky	4
thick	2
tough	2
unpleasant	1
unyielding	1
varnished	1
vinyl	1
warm	1
wet	1
yucky	1

APPENDIX 4: DENDROGRAM OF CLUSTERS

