

---

# **A Code of Practice for the Calibration of Industrial Process Weighing Systems**

---

The Institute of Measurement and Control  
87 Gower Street  
London  
WC1E 6AF

WGC0496

Originally published 1996  
Reviewed and re-issued 2003  
Reviewed and re-issued 2011

**WEIGHING  
& FORCE  
MEASUREMENT  
PANEL**





## COMMITTEE RESPONSIBLE FOR THIS CODE OF PRACTICE

This Institute of Measurement and Control Code of Practice has been prepared by the Weighing Group reporting to the Physical Measurements Panel and adopted by the United Kingdom Weighing Federation. The persons listed below served as members of the Weighing Group in preparing this Document.

U Erdem, Chairman	Negretti Automation Ltd
P Zecchin, Deputy Chairman	Nobel Systems Ltd
J Anthony	UK Weighing Federation
T Bowen	Davy International Weighing Systems
N S Fox	Warwickshire CC, TSD
D Green	DCG Associates
D Hayward	UKAS
R F Jenkins	National Physical Laboratory
C M Marklew	Nova Weigh Ltd
D J Phillips	QSRMC
J R Pugh	Glasgow Caledonian University
C G Whittingham	British Steel, Scunthorpe

This Code of Practice is subject to review at any time by the responsible technical group of the Institute. It was reviewed and re-issued in PDF format in 2003, and then subjected to a major review and re-issue in 2011. Members of the Weighing and Force Measurement Panel at the time of the 2011 review were:

Andy Knott, Chairman	National Physical Laboratory
Ural Erdem, Deputy Chairman	Consultant
Thomas Allgeier	Flintec UK Ltd
Mike Baker	Sherborne Sensors Ltd
Tony Bowen	AB Measurement & Control Solutions
Paul Dixon	National Measurement Office
Peter Harrison	UKAS
Mark Hopkins	Procon Engineering
John Pugh	Glasgow Caledonian University
David Smith	Avery Weightronix Ltd
Clarry Whittingham	Tata Steel

The Institute welcomes all comments on this Document and requests that these be addressed to the Institute. Users of this Institute of Measurement and Control Code of Practice shall be responsible for its correct use and application.

ISBN 0 904457 23 0

### **WARNING**

**DUE CONSIDERATION SHALL BE GIVEN TO THE SAFETY AND ENVIRONMENTAL ASPECTS OF ALL OPERATIONS AND PROCEDURES DURING THE CALIBRATION. FORMAL APPROVAL SHALL BE SOUGHT WHEN THE CALIBRATION IS PLANNED IN A POTENTIALLY HAZARDOUS AREA.**

<b>CONTENTS</b>		<b>PAGE</b>
<b>1</b>	<b>FOREWORD</b>	<b>5</b>
<b>2</b>	<b>SCOPE</b>	<b>5</b>
<b>3</b>	<b>TERMS AND DEFINITIONS</b>	<b>5</b>
<b>4</b>	<b>GENERAL REQUIREMENTS FOR CALIBRATION</b>	<b>13</b>
<b>4.1</b>	<b>GENERAL</b>	<b>13</b>
<b>4.2</b>	<b>MEASUREMENT STANDARDS</b>	<b>13</b>
<b>4.3</b>	<b>TRACEABILITY OF CALIBRATION EQUIPMENT</b>	<b>13</b>
<b>4.4</b>	<b>METHOD OF LOADING</b>	<b>13</b>
<b>4.4.1</b>	<b>General considerations</b>	<b>13</b>
<b>4.4.2</b>	<b>Calibration</b>	<b>13</b>
<b>4.4.3</b>	<b>Revalidation</b>	<b>14</b>
<b>4.4.4</b>	<b>Warm up period</b>	<b>14</b>
<b>4.4.5</b>	<b>Preloading</b>	<b>14</b>
<b>4.5</b>	<b>TEMPERATURE EFFECTS</b>	<b>14</b>
<b>4.6</b>	<b>EFFECTS OF ECCENTRIC LOADING</b>	<b>14</b>
<b>4.7</b>	<b>RECORDS</b>	<b>14</b>
<b>4.8</b>	<b>FREQUENCY OF CALIBRATION</b>	<b>14</b>
<b>4.8.1</b>	<b>Initial choice of confirmation intervals</b>	<b>14</b>
<b>4.8.2</b>	<b>Review of confirmation intervals</b>	<b>15</b>
<b>4.9</b>	<b>INDICATION OF CALIBRATION STATUS AND SEALING FOR INTEGRITY</b>	<b>15</b>
<b>4.10</b>	<b>CALIBRATION CERTIFICATE</b>	<b>15</b>
<b>5</b>	<b>METHODS OF CALIBRATION</b>	<b>16</b>
<b>5.1</b>	<b>CALIBRATION PROCEDURE USING STANDARD WEIGHTS</b>	<b>16</b>
<b>5.1.1</b>	<b>Introduction</b>	<b>16</b>
<b>5.1.2</b>	<b>Specific requirements prior to calibration</b>	<b>16</b>
<b>5.1.3</b>	<b>Calibration procedure</b>	<b>16</b>
<b>5.1.4</b>	<b>Uncertainty of calibration load</b>	<b>17</b>
<b>5.2</b>	<b>CALIBRATION PROCEDURE USING REFERENCE WEIGHTS</b>	<b>17</b>
<b>5.2.1</b>	<b>Introduction</b>	<b>17</b>
<b>5.2.2</b>	<b>Specific requirements prior to calibration</b>	<b>17</b>
<b>5.2.3</b>	<b>Calibration Procedure</b>	<b>17</b>
<b>5.2.4</b>	<b>Uncertainty of calibration load</b>	<b>17</b>
<b>5.3</b>	<b>CALIBRATION PROCEDURE USING SUBSTITUTE MATERIAL</b>	<b>17</b>
<b>5.3.1</b>	<b>Introduction</b>	<b>17</b>
<b>5.3.2</b>	<b>Specific requirements prior to calibration</b>	<b>18</b>
<b>5.3.3</b>	<b>Calibration procedure</b>	<b>18</b>
<b>5.3.4</b>	<b>Uncertainty of calibration load</b>	<b>18</b>
<b>5.4</b>	<b>CALIBRATION PROCEDURE USING FORCE TRANSFER METHOD</b>	<b>18</b>
<b>5.4.1</b>	<b>Introduction</b>	<b>18</b>
<b>5.4.2</b>	<b>Specific requirements prior to calibration</b>	<b>21</b>
<b>5.4.3</b>	<b>Calibration procedure</b>	<b>21</b>
<b>5.4.4</b>	<b>Uncertainty of calibration load</b>	<b>22</b>
<b>5.5</b>	<b>CALIBRATION PROCEDURE USING METERED FLOW</b>	<b>22</b>
<b>5.5.1</b>	<b>Introduction</b>	<b>22</b>
<b>5.5.2</b>	<b>Specific requirements prior to calibration</b>	<b>23</b>
<b>5.5.3</b>	<b>Calibration Procedure</b>	<b>23</b>
<b>5.5.4</b>	<b>Conversion of flow meter reading to actual flow</b>	<b>24</b>
<b>5.5.5</b>	<b>Uncertainty of calibration load</b>	<b>24</b>

5.5.6	Correction for density	25
5.6	<b>CALIBRATION PROCEDURE USING PROVING TANKS</b>	26
5.6.1	Introduction	26
5.6.2	Specific requirements prior to calibration	26
5.6.3	Calibration procedure	27
5.6.4	Uncertainty of calibration load	27
5.6.5	Correction for density	27
5.7	<b>CALIBRATION PROCEDURE USING METHODS REMOTE TO THE OPERATING INSTALLATION</b>	28
5.7.1	Introduction	28
5.7.2	Specific requirements prior to calibration	28
5.7.3	Calibration procedure	28
5.7.4	Uncertainty of calibration load	28
6	<b>QUALITY OF SERVICE</b>	29
A1.	<b>GENERAL CONSIDERATIONS</b>	30
A1.1	<b>INFLUENCE QUANTITIES</b>	30
A1.1.1	Pressure/Vacuum	30
A1.1.2	Temperature	30
A1.1.3	Structural effects	30
A1.1.4	Method of loading	30
A1.1.5	Climatic and local effects	30
A1.1.6	Mechanical effects	31
A1.1.7	Radiation and other electrical effects	31
A1.2	<b>PORTABLE WEIGHING SYSTEMS</b>	31
A1.3	<b>AIR BUOYANCY EFFECT</b>	31
A1.4	<b>WEIGHING SYSTEM INCORPORATING DUMMY LOAD CELLS OR PIVOTS</b>	32
A1.5	<b>INFLUENCE OF ZERO TRACKING</b>	32
A2.	<b>CALIBRATION OF WEIGHING SYSTEM COMPONENTS</b>	33
A2.1	<b>USE OF LOAD CELL SIMULATOR</b>	33
A2.1.1	Introduction	33
A2.1.2	Specific requirements	33
A2.1.3	Procedure	33
A2.1.4	Guidance on using a load cell simulator	33
A2.1.5	Uncertainty of simulated load	34
A2.2	<b>USE OF MILLIVOLT SOURCE</b>	34
A2.2.1	Introduction	34
A2.2.2	Specific requirements	34
A2.2.3	Procedure	34
A2.2.4	Uncertainty of simulated load	34
A2.3	<b>USE OF SHUNT RESISTORS</b>	35
A2.3.1	Introduction	35
A2.3.2	Specific requirements prior to calibration	35
A2.3.3	Procedure	35
A2.3.4	Guidance on using shunt calibration resistors	35
A2.4	<b>USE OF THEORETICAL CALCULATIONS</b>	35
A2.4.1	Introduction	35
A2.4.2	Specific requirements	36
A2.4.3	Procedure	36
A2.4.4	Guidance on the method of combining calibration data	36
A2.4.5	Uncertainty of calibration load	36

<b>A2.5</b>	<b>REVALIDATION OF LEVER SYSTEMS</b>	<b>37</b>
<b>A2.5.1</b>	<b>Introduction</b>	<b>37</b>
<b>A2.5.2</b>	<b>Specific requirements</b>	<b>37</b>
<b>A2.5.3</b>	<b>Procedure</b>	<b>37</b>
<b>A2.5.4</b>	<b>Uncertainty of applied load</b>	<b>37</b>
<b>A3.</b>	<b>PROCESSING OF CALIBRATION DATA</b>	<b>38</b>
<b>A3.1</b>	<b>Calculation of non-linearity using the “best straight line through zero” (BSLZ) method</b>	<b>38</b>
<b>A3.2</b>	<b>Calculation of non-linearity using the “terminal line” method</b>	<b>38</b>
<b>A3.3</b>	<b>Calculation of non-linearity (decreasing) using the BSLZ method</b>	<b>38</b>
<b>A3.4</b>	<b>Calculation of non-linearity (decreasing) using the terminal line method</b>	<b>38</b>
<b>A3.5</b>	<b>Calculation of hysteresis</b>	<b>38</b>
<b>A3.6</b>	<b>Calculation of combined error, using the BSLZ method</b>	<b>38</b>
<b>A3.7</b>	<b>Calculation of combined error, using the terminal line method</b>	<b>39</b>
<b>A3.8</b>	<b>Calculation of repeatability</b>	<b>39</b>
<b>A4.</b>	<b>TEST PROCEDURES AND PROCESSING OF TEST DATA</b>	<b>40</b>
<b>A4.1</b>	<b>Determination of eccentric loading effects</b>	<b>40</b>
<b>A4.2</b>	<b>Calculation of eccentric loading effects</b>	<b>40</b>
<b>A4.3</b>	<b>Determination of incremental error</b>	<b>40</b>
<b>A4.4</b>	<b>Calculation of incremental error</b>	<b>41</b>
<b>A5.</b>	<b>UNCERTAINTY OF CALIBRATION RESULTS</b>	<b>42</b>
<b>A6.</b>	<b>EXAMPLE OF CALIBRATION CERTIFICATE</b>	<b>44</b>
<b>A7.</b>	<b>CONVERSION FACTORS FOR MASS AND FORCE, AND A LIST OF USEFUL VALUES</b>	<b>47</b>
	<b>BIBLIOGRAPHY</b>	<b>48</b>
	<b>LISTS OF TABLES AND FIGURES</b>	
	<b>Table 1: Comparison of typical uncertainty of applied load for different methods of calibration</b>	<b>16</b>
	<b>Table 2: Density of pure air-free water as a function of temperature</b>	<b>25</b>
	<b>Table 3: Density of air-free mains water as a function of temperature</b>	<b>26</b>
	<b>Figure 1: Illustration of certain weighing terms (numbers in brackets refer to clause numbers)</b>	<b>10</b>
	<b>Figure 2: Generic industrial weighing system</b>	<b>11</b>
	<b>Figure 3: Representation of errors based on terminal straight line</b>	<b>11</b>
	<b>Figure 4: Representation of combined error based on best straight line through zero</b>	<b>12</b>
	<b>Figure 5: Representation of non-linearity based on best straight line through zero</b>	<b>12</b>
	<b>Figure 6: Example of calibration by force transfer standard in series</b>	<b>19</b>
	<b>Figure 7: Example of calibration by force transfer standard in series, using a pressure gauge as the load indicator</b>	<b>20</b>
	<b>Figure 8: Example of calibration by force transfer standard in series</b>	<b>20</b>
	<b>Figure 9: Example of calibration by force transfer standard in parallel</b>	<b>21</b>
	<b>Figure 10: Calibration by flow meter - general arrangement</b>	<b>23</b>
	<b>Figure 11: Density of water as a function of temperature</b>	<b>26</b>

# 1 FOREWORD

This Institute of Measurement and Control Code of Practice establishes uniform criteria for the calibration of industrial process weighing systems incorporating load cells as components in applications other than those covered by the Statutory requirements such as in trade weighing.

It gives recognition to the need for a comprehensive and authoritative document for the calibration of industrial process weighing systems.

This Document is a guide for technical personnel and organisations engaged in calibration of industrial process weighing systems. It is expected that the competence of the calibration authority is established and appropriate accreditation, such as to [BS EN ISO/IEC 17025](#), is obtained.

It is prepared to meet the requirements of the now well established and accepted [BS EN ISO 9000](#) series of Quality management and quality assurance standards.

The proposed guidelines are intended for those systems which are already commissioned and in good working order and comply with all the current safety and regulatory requirements as relevant.

# 2 SCOPE

This Code of Practice reviews various techniques for the calibration of industrial process weighing systems.

The methods described address static calibration of weighing systems. Calibration of dynamic weighing systems - such as belt weighers, in-motion weighbridges, and closed loop control of batched ingredients - is excluded. For information on calibration of dynamic weighing systems, please see [InstMC WFMP1010, A Guide to Dynamic Weighing for Industry](#).

Each method is described in a formal statement of procedure supplemented by practical application and performance topics.

The term 'Calibration', within the context of this Code of Practice means carrying out a set of operations, which establish, under reported conditions, the relationship between the weighing system output and corresponding known values of load applied to the weighing structure. The result of the calibration is reported in a formal document entitled **calibration certificate** or **certificate of calibration**.

The data obtained as a result of the calibration operation may be used to estimate the weighing system errors or adjust the system output to an agreed specific value.

# 3 TERMS AND DEFINITIONS

This Code of Practice provides recommended terminology and definitions pertaining to the calibration of industrial process weighing systems. The following definitions have been limited to those widely used in the Weighing Industry and also those which are necessary for the calibration of the industrial weighing systems.

Where appropriate, these terms and definitions are based on [BS EN 45501, Specification for metrological aspects of non-automatic weighing instruments](#) and [JCGM 200, International vocabulary of metrology - Basic and general concepts and associated terms \(VIM\)](#).

Refer to Figure 1, Figure 2, Figure 3, Figure 4, and Figure 5 for diagrammatic/graphical representation of certain weighing terms.

- 3.1 **Accuracy of measurement:** the closeness of the agreement between the result of a load measurement and the true value of the load. The term is unhelpful and is not freely used here. The use of terms such as **uncertainty of measurement**, **non-linearity**, **combined error**, and **hysteresis** is preferred.
- 3.2 **Adjustment:** the operation intended to bring the weighing system output within a specified agreement to the load applied.

- 3.3 Applied load:** within the context of this Document, the load applied to the weighing system for the purpose of calibration.
- 3.4 Blind amplifier:** see **Transmitter**
- 3.5 Calibration:** the set of operations which establish under specified conditions the relationship between the values of load applied and the corresponding value of the weighing system output. Note: Calibration does not include adjustment. See 3.2.
- 3.6 Calibration certificate:** a formal and structured document reporting the results of calibration and, where appropriate, relevant findings and observations. See A6.
- 3.7 Calibration curve:** the presentation of calibration results in graphical format.
- 3.8 Capacity, maximum operating:** the maximum load that will be applied to the load receiving element under normal operating conditions.
- 3.9 Capacity, minimum operating:** value of load applied to the load receiving element, below which the weighing results may be subject to an excessive relative error.
- 3.10 Capacity, rated:** the maximum load specified by the manufacturer that can be applied to the load receiving element.
- 3.11 Check rod:** a mechanical restraint, designed to prevent tipping or excessive movement of a weighing structure. Such restraints should not interfere with normal movement of the weighing structure.
- 3.12 Combined error, (Best straight line):** the maximum deviation of weighing system output obtained for increasing and decreasing applied loads, from a ‘best fit’ straight line passing through zero applied load, computed using the method of least squares. See Figure 4.
- 3.13 Combined error, (Terminal):** the maximum deviation of weighing system output, obtained for increasing and decreasing applied loads, from the line drawn between zero applied load and maximum applied load. See Figure 3.
- 3.14 Conventional value:** a value of a quantity which for a given purpose may be substituted for the true value. A conventional value is in general regarded as sufficiently close to the true value for the difference to be insignificant for the given purpose. Conventional weight value is a mathematical value fixed by guidelines. These values are allocated to weights and defined according to [OIML Document D 28](#).
- 3.15 Corner test:** see **Eccentricity test**
- 3.16 Creep:** the change in weighing system output occurring with time, while under constant load, with all environmental and other influence quantities remaining constant.
- 3.17 Creep recovery:** the change in weighing system output occurring with time, after a load has been removed, with all environmental and other influence quantities remaining constant.
- 3.18 d Division:** see **Scale interval**
- 3.19 Dead load:** the fixed weight of the weighing structure supported by the load cells.
- 3.20 Dead weight:** a weight of any shape or density calibrated against standard weights, cf. **Reference weight**
- 3.21 Deflection:** the displacement of the weighing structure caused by a change in the applied load.
- 3.22 Dormant weigh scale:** see **Fixed location scale**
- 3.23 Drift:** the slow variation with time of the output of the weighing system with all other influence quantities remaining constant. This term should not be confused with **creep**.
- 3.24 Dummy load cell:** a load support which does not contribute to the output of the weighing system. A dummy load cell is not necessarily a permanent part of the installation. cf. **Pivot**.
- 3.25 Dynamic load:** a load caused by motion or impact.

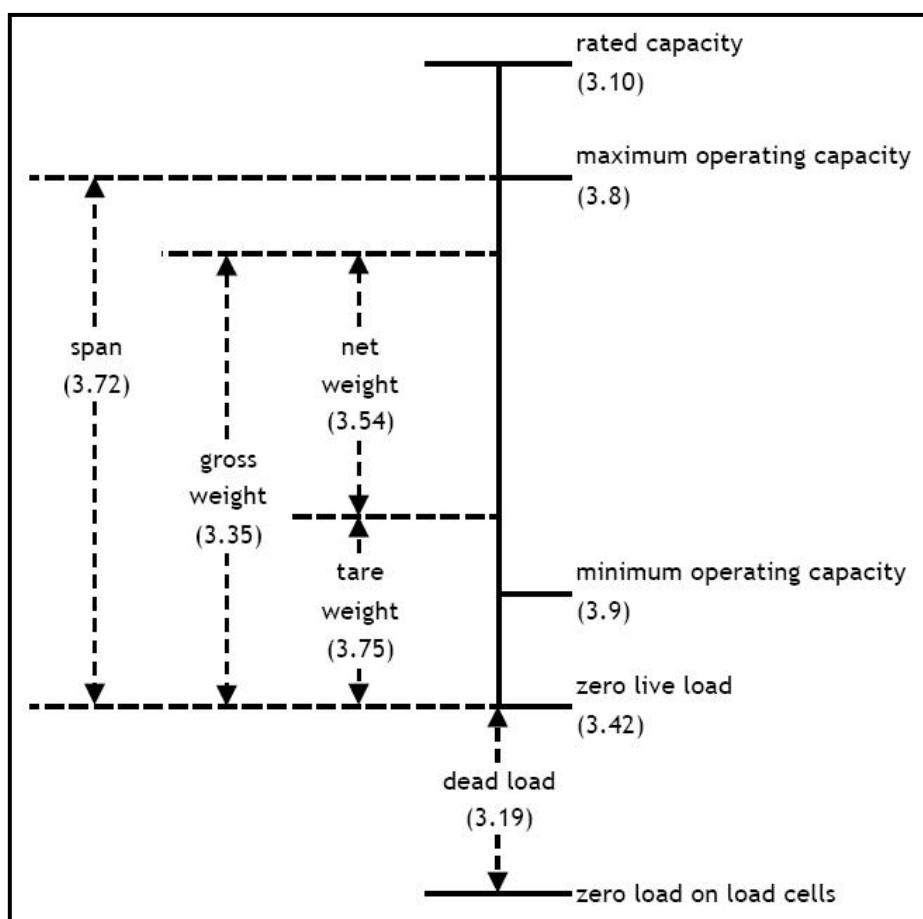


- 3.26 Eccentricity test:** a test of a weighing structure in which the load is distributed asymmetrically in a specified way.
- 3.27 Error:** a deviation in relation to a true value. For the purpose of this Document the true value is considered to be equal to the conventional value.
- 3.28 Error, incremental:** the difference between the indicated value of a load change and the true value of that load change.
- 3.29 Excitation voltage:** the voltage applied to the load cell(s)
- 3.30 Filtering:** dynamic conditioning of the load cell signal.
- 3.31 Fixed location scale:** any weighing system which is not readily movable from the location where installed, as differentiated from a portable one. or one which may be moved from place to place comparatively easily.
- 3.32 Flexible coupling:** a mechanical means of attaching pipework or services to a weighing structure intended to minimise force shunt errors.
- 3.33 Flexure:** a uniform thin plate or band designed to maintain correct loading and alignment of a weighing structure.
- 3.34 Force shunt:** mechanical interference between a weighing structure and its support structure such as pipework and tie rods.
- 3.35 Gross weight:** the output of the weighing system with no automatic or preset tare device in operation. This does not include dead load.
- 3.36 Hysteresis:** the difference between the measurements of weighing system output for the same applied load, one output being obtained by increasing the load from zero load, the other by decreasing the load from the maximum applied load.
- 3.37 In-flight material:** additional material being supplied to or taken from a weighing system after an action is taken to stop the flow.
- 3.38 Indicating device:** part of the measuring chain utilised to display weighing system output.
- 3.39 Influence factor:** environmental element that may alter or interrupt the output of the weighing system such as temperature, humidity, radio frequency interference, barometric pressure, electric power.
- 3.40 Influence quantity:** a quantity that is not the measured quantity but affects the measurement.
- 3.41 Junction box:** within the context of this Document, a housing for electrical connection of load cells in a weighing system.
- 3.42 Live load:** the part of the load intended to be output.
- 3.43 Load:** the force applied to the load cell(s). Within the context of this Document this force is expressed in terms of weight.
- 3.44 Load bearing structure:** the structure designed to support the load cells and weighing structure.
- 3.45 Load cell:** a device which produces an output signal related to the applied load. The load cell may utilise any physical principle including but not limited to, electricity, magnetism and pneumatic, or combinations thereof.
- 3.46 Load receiving element:** the element of a weighing system intended to receive the load to be measured, such as a hopper, silo or ladle.
- 3.47 Load receptor:** see **Load receiving element**.
- 3.48 Load test (increasing):** the basic performance test for a weighing system in which increments of calibration load are successively added to the load receiving element.
- 3.49 Load test (decreasing):** the basic performance test for a weighing system in which decrements of calibration load are successively removed from the load receiving element.

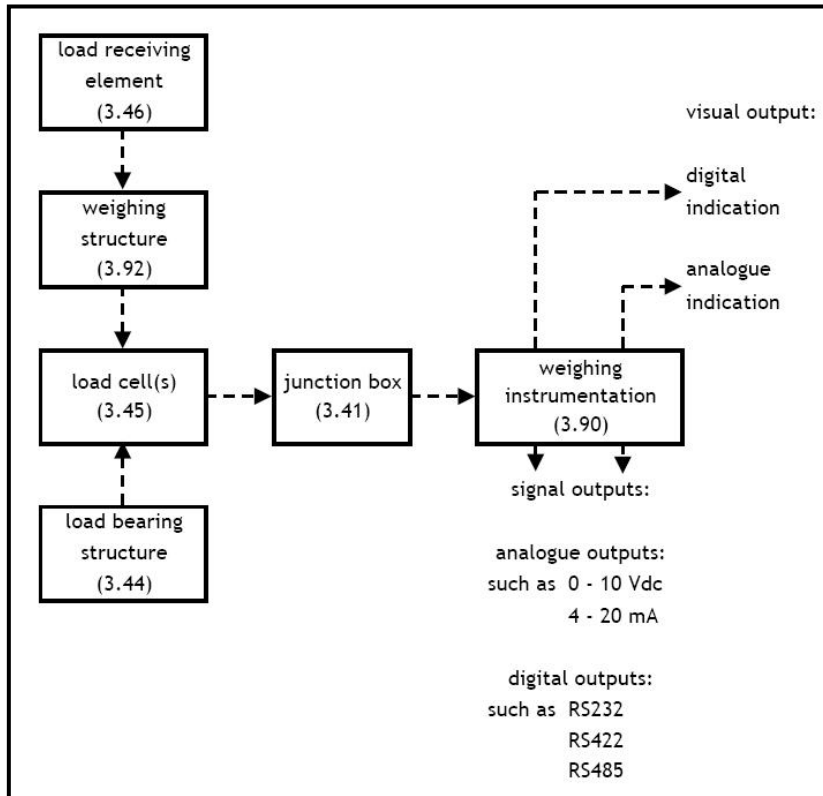
- 3.50 Mass:** the quantity of material in a body, as different from its size or weight.
- 3.51 Measuring chain:** the series of components which constitute the path for the weight measurement signal from the load receiving element to the weighing instrumentation output that are a permanent part of the weighing system.
- 3.52 Motion detection:** the process of sensing a rate of change of applied load.
- 3.53 National standard:** a standard recognised by an official national decision to serve in a country as the basis for fixing the value of all standards of the quantity concerned.
- 3.54 Net weight:** the output of a weighing system after the operation of a tare device.
- 3.55 Nonlinearity (increasing), best straight line:** the deviation of weighing system output, obtained for increasing applied loads from a ‘best fit’ straight line passing through zero applied load. computed using the method of least squares. See Figure 5.
- 3.56 Nonlinearity (increasing), terminal:** the deviation of weighing system output. obtained for increasing loads, from the line drawn between zero and maximum applied load. See Figure 3.
- 3.57 Nonlinearity (decreasing), best straight line:** the deviation of weighing system output obtained for decreasing loads from a computed ‘best fit’ straight line passing through zero applied load, using the methods of least squares. See Figure 5.
- 3.58 Nonlinearity (decreasing), terminal:** the deviation of weighing system outputs, obtained for decreasing loads only, from the line drawn between zero load and maximum live load. See Figure 3.
- 3.59 Pivot:** an element of a weighing system which supports load but does not itself contribute to the output, cf. **Dummy load cell**.
- 3.60 Proving tank:** a delivery measure sometimes known as an automatic pipette used to deliver a known volume of liquid within specified limits.
- 3.61 Rationalisation:** within the context of this Document, the process of adjusting the load cell rated output and output resistance to stated criteria for a particular load cell.
- 3.62 Reference weight:** an object of any shape or density, of known mass, normally calibrated against standard weights. cf. **Dead weight**.
- 3.63 Remote sensing / 6-wire technique:** a method of compensating for load cell excitation voltage changes in connecting cables. Some weighing instrumentation compensates for voltage changes by adjusting the excitation voltage, other instrumentation amplifies the load cell return signal.
- 3.64 Repeatability:** the measure of agreement between the results of successive measurements of weighing system output for repeated applications of a given calibration load in the same direction.
- 3.65 Resolution:** the smallest change in weighing system output that can be meaningfully distinguished.
- 3.66 Revalidation:** a test performed on the weighing system to verify its performance at specified load(s).
- 3.67 Scale:** see **Weighing system**
- 3.68 Scale interval, analogue:** the difference between the values corresponding to consecutive scale marks.
- 3.69 Scale interval, digital:** the difference between consecutive indicated values.
- 3.70 Sensitivity:** the change in the output of the weighing system divided by the corresponding load change.
- 3.71 Shift test:** see **Eccentricity test**.
- 3.72 Span:** the difference between the maximum operating capacity and the zero live load.
- 3.73 Standard weight:** weight which complies with the appropriate recommendations of the International Organisation of Legal Metrology (OIML).

- 3.74 Stay rod:** see **Tie rod**
- 3.75 Tare, n:** The weight of a transport container which may be required to be subtracted from the gross weight.
- 3.76 Tare, v:** 1) to weigh in order to ascertain the tare 2) the action of adjusting out the weight of a container and/ or its contents, so that the weighing system output represents net weight directly.
- 3.77 Tare, automatic:** the process or means for automatically resetting the weighing system output to zero at any point in the weighing range.
- 3.78 Tare, preset:** a fixed tare weight, which is subtracted from either the gross or net weight value
- 3.79 Temperature effect on span:** the change of weighing system span for a specified change of temperature at steady state conditions.
- 3.80 Temperature effect on zero live load:** the change of zero live load output for a specified change of temperature at steady state conditions.
- 3.81 Test weight car:** a car for testing scales, consisting essentially of a body on wheels and provided with the required accessories for transportation. whose aggregate weight is known and maintained within specified limits.
- 3.82 Tie rod:** a rod or flexure used to restrain movement of the weighing structure in a horizontal direction.
- 3.83 Traceability:** the step by step route by which measurements made on a weighing system, during calibration or testing, are traceable to SI unit standards (see 7.3.2 of [BS EN ISO 10012:2003](#)). Traceability may be achieved either directly or indirectly, through a hierarchical chain such as that provided by a calibration laboratory that has UKAS accreditation.
- 3.84 Transfer standard:** a standard used as a intermediary to compare standards. Within the context of this Document, it is a force measuring system, calibrated in a Force Standard Machine (see Bibliography), typically comprising load cell(s) and weighing instrumentation, utilised for calibration of a weighing system.
- 3.85 Transmitter:** weighing instrumentation with the primary function of providing an output to another device.
- 3.86 Uncertainty of measurement:** an estimate characterising the range of values within which the true value of a physical quantity lies.
- 3.87 Warm-up period:** the time interval after power is applied to the weighing system, after which it is capable of achieving stable readings consistent with its performance specification.
- 3.88 Weight:** see **Load** For full definition refer to Clause 3.2 of the [InstMC Guide to the Measurement of Force](#).
- 3.89 Weighing:** within the context of this Document, it is the measurement of downward force exerted by the mass which the load cells(s) support.
- 3.90 Weighing instrumentation:** an electronic system that supplies excitation voltage to the load cell(s) and processes the output to provide indication and/or electrical output.
- 3.91 Weighing range:** see **Span**
- 3.92 Weighing structure:** part of a weighing system supported by the load cells.
- 3.93 Weighing system:** a load measuring chain comprising weighing structure, load cell[s], and weighing instrumentation. See Figure 2.
- 3.94 Zero return:** the difference in zero load output before and after a weighing system has been loaded. With all environmental conditions and other influence quantities remaining constant.
- 3.95 Zero-setting device:** device for setting the weighing system output to zero when there is no load on the load receiving element.
- 3.96 Zero-setting device, automatic:** device for setting the weighing system output to zero automatically without the intervention of an operator.

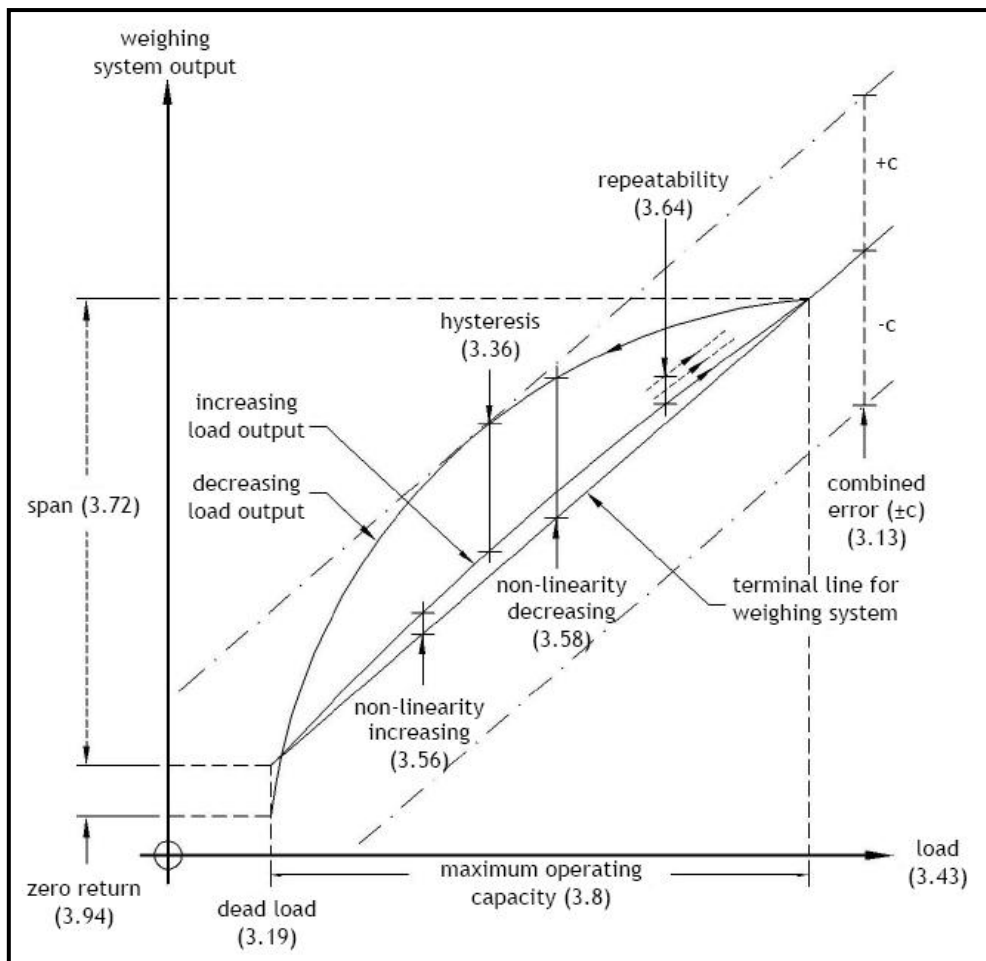
- 3.97 **Zero-setting device, initial:** device for setting the weighing system output to zero automatically at the time the system is switched on and before it is ready for use.
- 3.98 **Zero-setting device, non-automatic:** device for setting the weighing system output to zero by an operator.
- 3.99 **Zero stability:** the measure to which the weighing system maintains its output reading over a specified period of time at constant temperature and at zero load.
- 3.100 **Zero-tracking device:** Device for maintaining the zero indication within certain limits automatically.
- 3.101 **Zero-tracking window:** the limits (+ and - ) over which the zero tracking device operates, typically  $\pm 2\%$  of span.



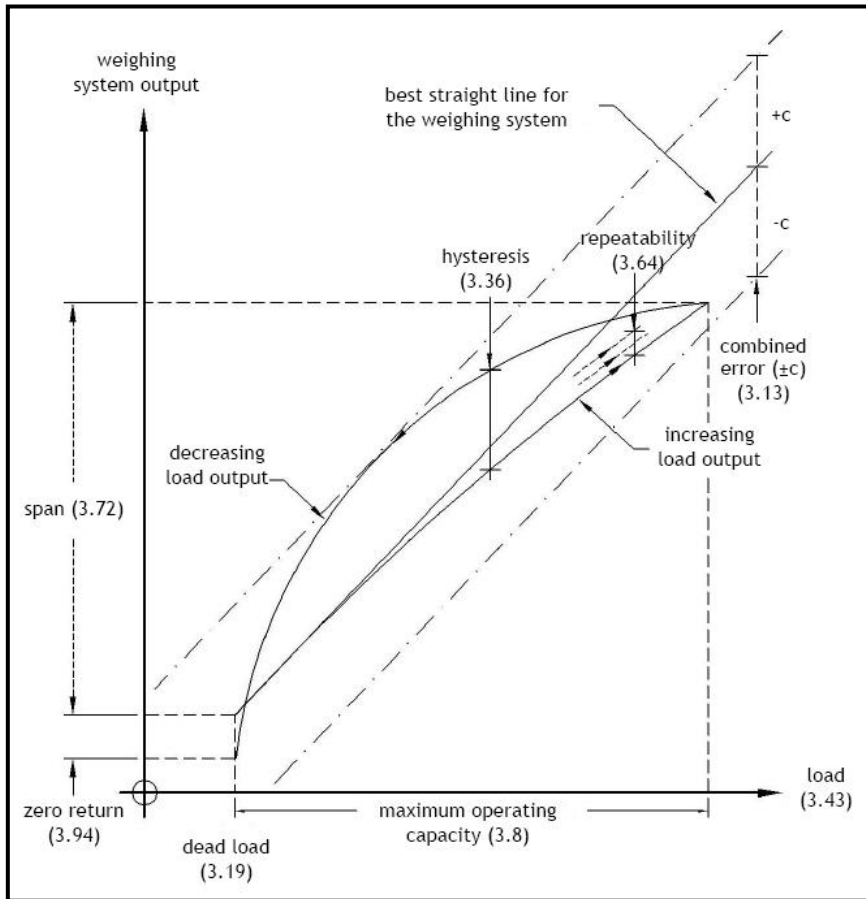
**Figure 1:** Illustration of certain weighing terms (numbers in brackets refer to clause numbers)



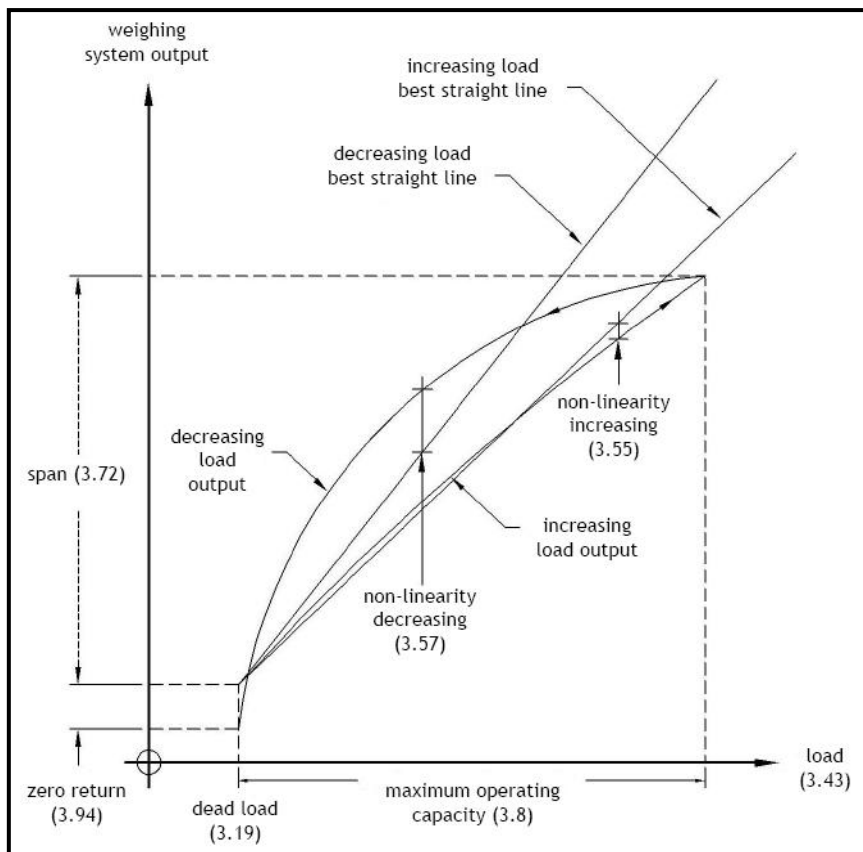
**Figure 2:** Generic industrial weighing system



**Figure 3:** Representation of errors based on terminal straight line



**Figure 4:** Representation of combined error based on best straight line through zero



**Figure 5:** Representation of non-linearity based on best straight line through zero

## **4 GENERAL REQUIREMENTS FOR CALIBRATION**

### **4.1 GENERAL**

The weighing system will have been installed and commissioned as appropriate prior to calibration. It is suggested that the system should have been in operation for a sufficient length of time for the mechanical installation to have been proven to operate satisfactorily and for the load cell(s) to have been subjected to normal operating loads.

If the location of the weighing system is classified as having a potentially explosive atmosphere, all electrical equipment taken into this area should have approval certificates appropriate for the area.

The general condition and status of the weighing system, if appropriate, may be reported in the calibration certificate. Particular attention should be given to any material which may be present in the load receiving element at the start of calibration. All parts of the measuring chain should be uniquely identified by serial numbers and these numbers should be stated in the calibration certificate. If an item does not have a serial number, mark it with a unique identifier and record this in the calibration certificate.

Where possible, prior to calibration, cognisance should be taken of guidance and recommendations from the supplier of the weighing system.

### **4.2 MEASUREMENT STANDARDS**

In general, the uncertainty of measurement of the equipment used for the calibration should be less than 1/3 of the specified or expected value of the uncertainty of the weighing system being calibrated.

### **4.3 TRACEABILITY OF CALIBRATION EQUIPMENT**

The forces applied to the load receiving element and, if used, any measuring instrument or components used in the calibration of the weighing system need to demonstrate traceability (see clause 3.83), supported by valid calibration certificates.

### **4.4 METHOD OF LOADING**

#### **4.4.1 General considerations**

4.4.1.1 The calibration activity as detailed in the Calibration Procedure sections of this Document should be a continuous operation without any change in the calibration conditions.

4.4.1.2 The time taken to apply and remove the calibration loads should, as far as practicable, be equal. At each calibration load, the applied load and the corresponding output of the weighing system is recorded, at substantially equal periods of time after the application or removal of the load. However, if this is not possible or practicable, the periods used should be reported in the calibration certificate.

4.4.1.3 The calibration loads should be placed on the load receiving element so as to replicate as far as practicable the normal operational load distribution.

#### **4.4.2 Calibration**

The calibration is to be performed using either of the following methods:

##### **4.4.2.1 Three run method**

A minimum of five substantially equally-spaced loads, covering the weighing range, are applied in ascending order and then removed, with the output at zero load at the completion of the run also being recorded. Where hysteresis, non-linearity (decreasing), or combined error are to be determined, the calibration loads are to be removed in the same steps as they were applied. This procedure is then repeated twice to give a total of at least eighteen data points (the initial zero load output is recorded for reference).

##### **4.4.2.2 Single run + repeatability method**

A minimum of five substantially equally-spaced loads, covering the weighing range, are applied in ascending order once only and then removed. Where hysteresis, non-linearity (decreasing), or combined error are to be determined, the calibration loads are to be removed in the same steps as they were applied. Additionally, a repeatability test is carried out at a load not less than 20 % of the span and repeated at least twice more to give three further data points.

#### **4.4.3 Revalidation**

The tests performed subsequently to verify the weighing system calibration may be simplified, with the agreement of the user. The uncertainty of measurement may be greater than that related to the calibration. Such tests may be sufficient to establish the consistency of the performance of the weighing system.

#### **4.4.4 Warm up period**

It is important to allow sufficient time for temperature stabilisation of the measuring chain prior to calibration. In deciding the minimum warm up time, cognisance should be taken of guidance and recommendations from the manufacturer or supplier of the system. In the absence of any such recommendation, the calibration authority decides the warm up period. The warm up period is to be stated in the calibration certificate.

#### **4.4.5 Preloading**

It is recommended that, where possible, a preload substantially equal to the maximum operating capacity should be applied and this preload should be reported in the calibration certificate. If the weighing system has been in service and is already operating normally, preloading may be omitted.

### **4.5 TEMPERATURE EFFECTS**

Temperature is an important influence factor affecting process weighing systems. Temperature changes will have an effect on:

1. load cells
2. instrumentation and interconnecting cables
3. the mechanics of the system.

The overall weighing system temperature effect will be a complex combination of the above factors. It is therefore difficult to quantify the effect of temperature change on weighing system output and as a result no provision is made within this Document to calculate the temperature effects.

If the calibrating authority or user considers the temperature effects to be important or significant then the temperature at appropriate locations should be measured both before and after the calibration and reported in the calibration certificate. Note that any measuring equipment used must comply with 4.3, traceability of calibration equipment.

### **4.6 EFFECTS OF ECCENTRIC LOADING**

If it is possible for the system, in use, to be subjected to eccentric loads, an eccentricity test should be carried out and, if appropriate, consideration given to the likely positioning of loads in service, compared with the location of test loads applied during calibration processes. An example of a system which would not require an eccentricity test is one used solely to weigh self-levelling product.

### **4.7 RECORDS**

All observations and calculations should be clearly and permanently recorded at the time they are made. Entries on the data collection or recording forms are to be signed by the person making them. Where mistakes occur in records or calculations, the mistakes should be crossed out (not erased, made illegible, or deleted), with the correct value being entered alongside. These corrections are to be signed by the person making them.

### **4.8 FREQUENCY OF CALIBRATION**

The weighing system is to be recalibrated if it has been repaired, modified, or subjected to any adjustment. It should also be recalibrated at periodic intervals.

[OIML D 10](#) (also ILAC-G24) presents in detail methods of determining periodic confirmation intervals. For the sake of completeness a summary of these appears here.

#### **4.8.1 Initial choice of confirmation intervals**

This is governed by engineering intuition taking into account factors like:

1. Manufacturer's recommendation.



2. Frequency and manner of use.
3. Environmental influence.
4. Accuracy sought.

#### **4.8.2 Review of confirmation intervals**

The initially chosen intervals should be reviewed to achieve a sensible balance between cost and risk.

[OIML D 10](#) presents five methods of review from which the user can select the most appropriate.

4.8.2.1 Automatic or 'staircase' adjustment: in which the confirmation interval is increased if the equipment is found to be within tolerance, or conversely reduced if outside tolerance.

4.8.2.2 Control chart: in which the same chosen calibration points from successive calibrations are plotted against time. These plots are then treated statistically to predict the drift in calibration and hence determine an efficient recalibration interval.

4.8.2.3 Calendar time: in which larger numbers of systems are grouped according to their predicted stability and assigned an initial confirmation interval. The review then looks at the proportion of nonconforming returns over a period in order to adjust the confirmation interval for the whole group.

4.8.2.4 'In-use' time: this is a variation of the above methods but utilising actual hours in use as the confirmation interval rather than elapsed calendar time.

4.8.2.5 In-service or 'black-box' testing: this is a variation on methods 1 & 2 in which certain critical parameters are checked between full confirmations using some form of portable calibration equipment. Clearly nonconformance at this level would prompt a full confirmation.

#### **4.9 INDICATION OF CALIBRATION STATUS AND SEALING FOR INTEGRITY**

At the completion of the calibration, the calibrating authority attaches a 'calibrated' label to the appropriate part(s) of the system.

The user should take steps to prevent any adjustments or modifications which may affect the calibration. It is the responsibility of the user to identify and visually indicate the calibration status of the system by the use of a suitable label(s) showing the following data: calibration certificate number, date of calibration, and next calibration date.

#### **4.10 CALIBRATION CERTIFICATE**

When a weighing system has been calibrated, the calibration authority issues a calibration certificate which contains at least the following information:

1. unique serial number
2. issue date
3. customer's or user's address
4. customer's or user's reference
5. calibration authority's reference
6. calibration authority's qualification details
7. whether the calibration certificate is for calibration or revalidation
8. description of the weighing system under calibration
9. date of calibration
10. reference to previous calibration if known
11. method of calibration
12. statement of traceability
13. results of calibration
14. results of calibration 'as found' and if any adjustment carried out on calibration parameters
15. the uncertainty of calibration loads

Any other data which the calibrating authority deems relevant may also be included in the certificate.

A sample calibration certificate is given in Annex A6.

## 5 METHODS OF CALIBRATION

Table 1 gives a comparison of uncertainty of applied load for different methods of calibration listed in this section.

**Table 1:** Comparison of typical uncertainty of applied load for different methods of calibration

CALIBRATION METHOD	TYPICAL EXPANDED UNCERTAINTY OF CALIBRATION LOAD AS % OF LOAD APPLIED
Standard weights (5.1)	0.005 % to 0.050 %
Reference weights (5.2)	0.025 %
Substitute material (5.3)	0.025 %
Force transfer method (5.4)	0.050 %
Metered flow (5.5)	0.030 %
Proving tanks (5.6)	0.015 %
Remote calibration (5.7)	0.010 %

Note: Refer to subsection 4.2 for the required uncertainty of measurement for the weighing system under calibration. A particular calibration method may introduce additional uncertainties. These are referred to in the individual calibration procedures. It may therefore be necessary to select a factor greater than the value of three specified in subsection 4.2 in order to achieve a required level of confidence in the calibration.

### 5.1 CALIBRATION PROCEDURE USING STANDARD WEIGHTS

#### 5.1.1 Introduction

This procedure may be used to calibrate a weighing system that can physically accept standard weights.

The method of loading and distribution of load may lead to results that are not fully representative of normal operating conditions. This factor is of particular importance if the weighing structure incorporates dummy load cells or pivots. It is therefore recommended that an eccentricity test be conducted prior to calibration. This is for two distinct reasons:-

1. To determine the likely influence of load distributions on the uncertainty of the calibration process
2. To identify the effect of differing load distributions in relation to the subsequent weighing accuracy in service

A test procedure for the determination of eccentric loading effects is detailed in Annex A4 of this document.

#### 5.1.2 Specific requirements prior to calibration

5.1.2.1 The calibration authority needs to satisfy itself of the safety of handling standard weights and the suitability of the structure to support those weights.

5.1.2.2 Where necessary the weighing structure may be temporarily modified to accept standard weights provided that the additional tare weight complies with the traceability requirements given in subsection 4.3.

#### 5.1.3 Calibration procedure

5.1.3.1 With zero calibration load applied, check that the weighing system output is stable and then record the output.

5.1.3.2 A series of loads is applied, each load being distributed over the weighing structure in a manner that as closely as possible replicates normal operating conditions. Loads are applied in steps up to and including the maximum operating capacity, and the corresponding weighing system output recorded in accordance with subsection 4.4.

5.1.3.3 Where hysteresis, non-linearity (decreasing), or combined error are to be determined, the calibration loads are removed in the same steps, recording the weighing system output in accordance with subsection 4.4.

5.1.3.4 Attach a label to the weighing system in accordance with subsection 4.9.

#### **5.1.4 Uncertainty of calibration load**

The maximum permissible errors for standard weights are given in Table 1 of [OIML R 111-1](#). For the purpose of this Document, the expanded uncertainty of the calibration load is taken as the expanded uncertainty specified on the weights' calibration certificate.

### **5.2 CALIBRATION PROCEDURE USING REFERENCE WEIGHTS**

#### **5.2.1 Introduction**

This procedure may be used to calibrate a weighing system that can either not physically accept standard weights or when sufficient standard weights are not available. The method of loading and distribution of load may lead to results that are not fully representative of normal operating conditions. This factor is of particular importance if the weighing structure incorporates dummy load cells or pivots. It is therefore recommended that an eccentricity test be conducted prior to calibration. This is for two distinct reasons:-

1. To determine the likely influence of load distributions on the uncertainty of the calibration process
2. To identify the effect of differing load distributions in relation to the subsequent weighing accuracy in service

A test procedure for the determination of eccentric loading effects is detailed in Annex A4 of this document.

Where process material is used as the reference weight, care must be taken to ensure that all of the known weight of the reference material is transferred to the weighing system under calibration.

#### **5.2.2 Specific requirements prior to calibration**

5.2.2.1 The weighing structure may be temporarily modified to accept reference weights provided that the additional tare weight complies with the traceability requirements given in subsection 4.3.

5.2.2.2 The calibration authority needs to satisfy itself of the safety of handling reference weights and the suitability of the structure and equipment to support those weights.

#### **5.2.3 Calibration Procedure**

5.2.3.1 The reference weights are to be of known uncertainty of measurement and of defined traceability. The reference weights may be any material that the weighing structure is capable of receiving. It is recommended that the process material is used for this purpose.

5.2.3.2 With zero calibration load applied, check that the weighing system output is stable and then record it.

5.2.3.3 A series of loads is then applied, each being distributed over the weighing structure in a manner that as closely as possible replicates normal operating conditions. Loads are applied in steps up to and including the maximum operating capacity, and the corresponding weighing system outputs recorded in accordance with subsection 4.4.

5.2.3.4 Where hysteresis, non-linearity (decreasing), or combined error are to be determined, the calibration loads are to be removed in the same steps, recording the weighing system output in accordance with subsection 4.4.

5.2.3.5 Attach a label to the weighing system in accordance with subsection 4.9.

#### **5.2.4 Uncertainty of calibration load**

The uncertainty of calibration load is to be determined from the uncertainty of the weighing system used to calibrate the reference weights.

### **5.3 CALIBRATION PROCEDURE USING SUBSTITUTE MATERIAL**

#### **5.3.1 Introduction**

This procedure may be used to calibrate a weighing system that can physically accept some standard or reference weights but where the maximum operating capacity cannot practically be attained using weights alone.

The discontinuous nature of the method and the fact that it depends on the performance of the weighing system under test may introduce additional problems in the evaluation of observations and associated uncertainty.

The method of loading and distribution of load may lead to results that are not fully representative of normal operating conditions. This factor is of particular importance if the weighing structure is not fully supported by live load cells. However the use of substitute material closely resembling normal process material can greatly reduce these effects. It is considered that this method is not practical for decreasing load tests.

### **5.3.2 Specific requirements prior to calibration**

5.3.2.1 The calibrating authority needs to satisfy itself about the safety aspects of handling and supporting the initial load of standard weights.

5.3.2.2 Where necessary the weighing structure may be temporarily modified to accept the standard weights provided that the additional tare weight complies with the traceability requirements given in subsection 4.3.

5.3.2.3 A source of suitable substitute material should be available in an appropriate quantity and with an effective, safe, and consistent means of delivery and disposal.

5.3.2.4 Steps should be taken to ensure that the substitute material can be reliably retained in or on the load receiving element.

### **5.3.3 Calibration procedure**

5.3.3.1 With zero calibration load applied, check that the weighing system output is stable and record it.

5.3.3.2 A series of loads is then applied, each being distributed over the weighing structure in a manner that as closely as possible replicates normal operating conditions. Loads are to be applied in steps up to and including the maximum operating capacity and the corresponding weighing system outputs recorded in accordance with subsection 4.4.

5.3.3.3 Each load is applied using standard weights, and the corresponding weighing system output recorded.

5.3.3.4 The standard weights are then removed and re-applied at least twice, the weighing system output being recorded each time the weights are applied. The average output with weights applied is then calculated, together with the repeatability of the system (the spread of the measured values).

5.3.3.5 The standard weights are then removed and replaced by substitute material until the weighing system output is the same as the average output with the standard weights applied. The weight of the substitute material will therefore equal that of the standard weights and is to be recorded as such. The standard weights are then applied in addition to the substitute material and the weighing system output recorded.

5.3.3.6 Repeat step 5.3.3.4 and 5.3.3.5 until the maximum capacity is reached.

5.3.3.7 Attach a label to the weighing system in accordance with subsection 4.9.

### **5.3.4 Uncertainty of calibration load**

The uncertainty of the standard weights is calculated on the basis given in subsection 5.1.4

If reference weights are used, refer to clause 5.2.4 for determination of uncertainty of calibration load.

The uncertainty of the calibration load is also dependent on the uncertainty of measurement of the weighing system being calibrated. The repeatability value calculated in 5.3.3.4 also affects the uncertainty of the calibration load, and it should be noted that the contribution of this term will increase with load, in an approximately linear manner.

## **5.4 CALIBRATION PROCEDURE USING FORCE TRANSFER METHOD**

### **5.4.1 Introduction**

This procedure may be used to calibrate a weighing system that can physically accept a force transfer system to apply the calibration loads.

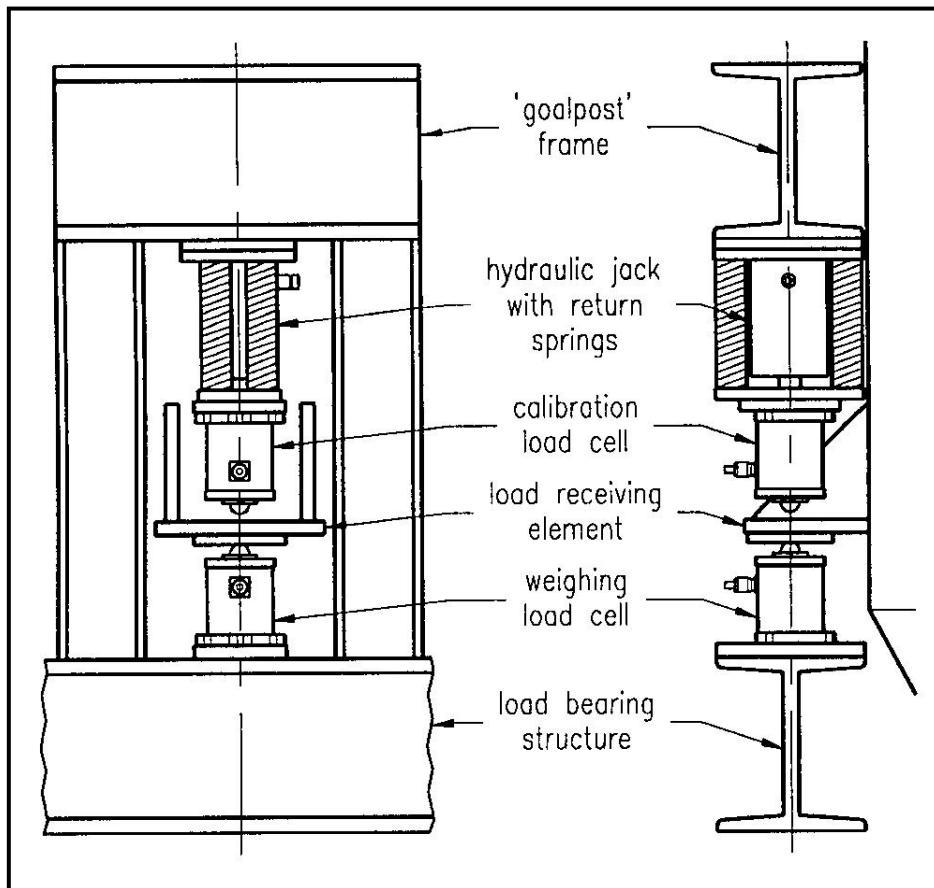
The method described uses hydraulic cylinders to apply the load, with either direct measurement of the hydraulic pressure or load cells, providing readings of the load applied. Other hardware implementations of the same principle such as hydraulic jacks or screw jacks can be used having due regard to the measurement uncertainty of the system employed. The use of

hydraulics can make it difficult to maintain a specific force – in such cases, a stable force near the nominal value can be applied and then the results can be mathematically corrected.

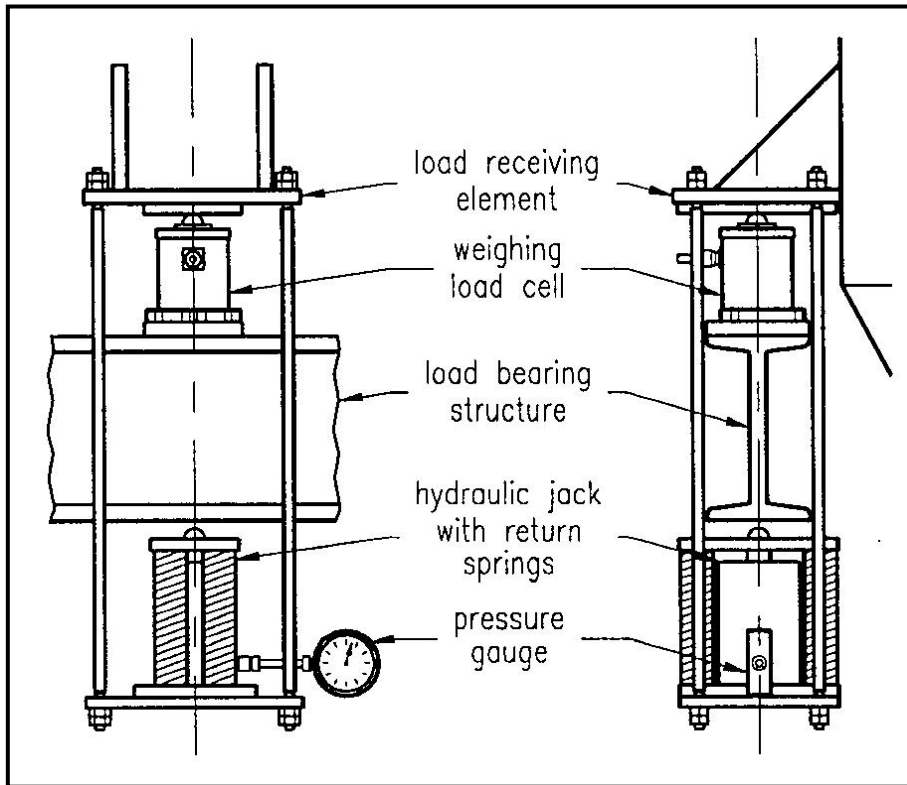
The method of loading and load distribution may lead to results that are not fully representative of normal operating conditions. This is of particular importance for weighing structures not fully supported by live load cells or where the weighing system output is normally perturbed by influence factors such as pipe work connections or structural movement.

Two ways of loading the weighing structure are described:

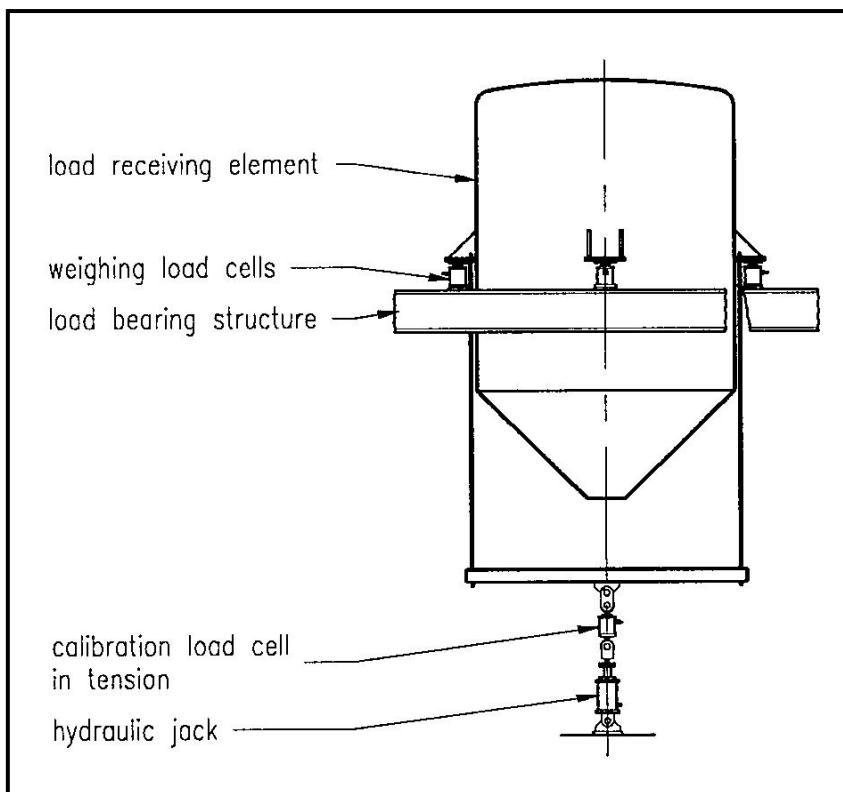
**Series application**, see Figure 6, Figure 7, and Figure 8, where the calibration load is applied to an unloaded weighing structure in series with the installed load cells. This method can facilitate the calculation of performance data for increasing and decreasing loads over the complete weighing range.



**Figure 6:** Example of calibration by force transfer standard in series

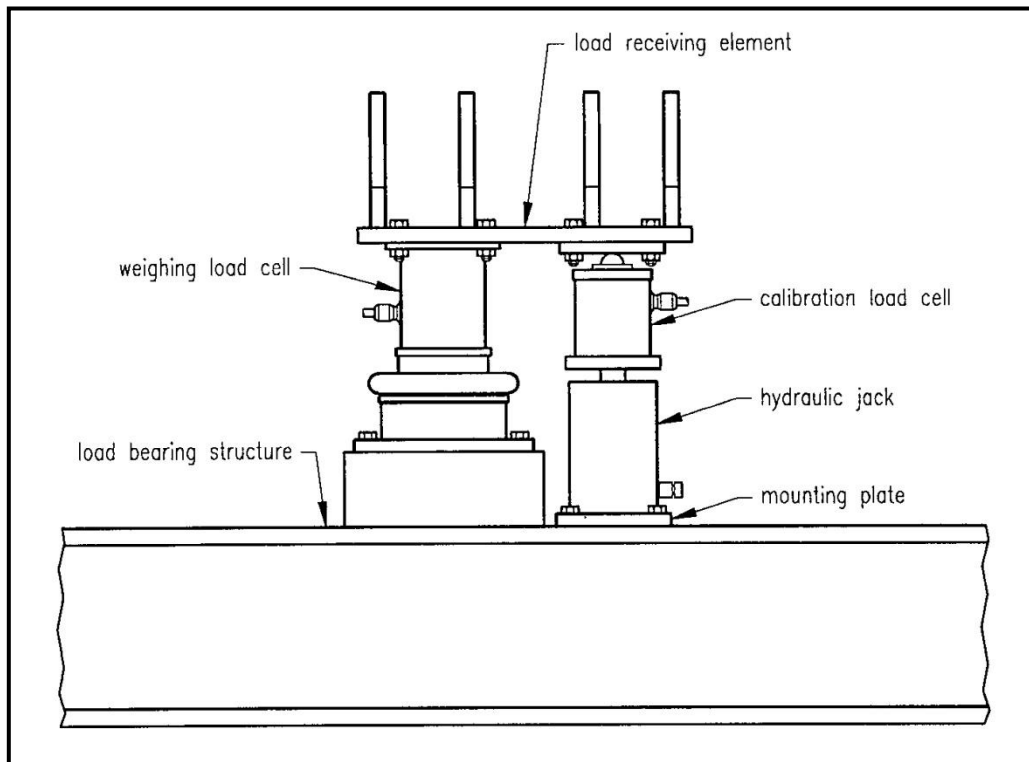


**Figure 7:** Example of calibration by force transfer standard in series, using a pressure gauge as the load indicator



**Figure 8:** Example of calibration by force transfer standard in series

**Parallel application**, see Figure 9, where the calibration load is provided by a loaded weighing structure and adjusted by the force transfer system, which is placed in parallel with the installed load cells. Zero live load is indeterminate using this method. As the calibration load is typically applied through different axes to the installed load cells, this method can introduce side forces and twisting moments to the structure, affecting the quality of the calibration.



**Figure 9:** Example of calibration by force transfer standard in parallel

## 5.4.2 Specific requirements prior to calibration

5.4.2.1 The calibration authority needs to satisfy itself about the safety aspects of handling the force application system.

Note: The use of high pressure hydraulic equipment carries hazards associated with leaking or otherwise poorly maintained or operated components and the lines connecting them. Special care should be taken in addition to the normal safety precautions associated with calibration procedures.

5.4.2.2 The force application system, including the associated system fittings, should be inspected for damage and cleanliness.

5.4.2.3 Where necessary, the weighing structure may be temporarily modified to accept the calibration equipment provided that any additional tare weight complies with the traceability requirements given in subsection 4.3.

## 5.4.3 Calibration procedure

### 5.4.3.1 Series method

5.4.3.1.1 With zero calibration load, check that the weighing system output is stable and record the output

5.4.3.1.2 Apply a series of test loads in steps up to and including the maximum operating capacity. Record both the weighing system output and the corresponding output of the force transfer system in accordance with subsection 4.4.

5.4.3.1.3 Where hysteresis, non-linearity (decreasing), or combined error are to be determined, remove the calibration loads in the same steps. Record both the weighing system output and the corresponding output of the force transfer system in accordance with subsection 4.4.

5.4.3.1.4 Repeat the operations described in 5.4.3.1.1 to 5.4.3.1.3 as required by subsection 4.4.

5.4.3.1.5 Attach a label to the weighing system in accordance with subsection 4.9.

### 5.4.3.2 Parallel method

This method utilises the fully loaded weighing structure to provide calibration loads.

5.4.3.2.1 With zero load on the force transfer system, load the weighing structure, as near as possible to its maximum operating capacity and check that the weighing system output is stable and record the output.

5.4.3.2.2 Activate the force transfer system to relieve the total load from the weighing system under calibration, or as near as practicable without completely unloading any of the individual load cells. Record both the weighing system output and the corresponding output of the force transfer system in accordance with subsection 4.4.

5.4.3.2.3 Apply a series of increasing loads to the weighing system by reducing the load supported by the force transfer system. Record both the weighing system output and the corresponding force transfer system output at each step in accordance with subsection 4.4.

5.4.3.2.4 Repeat the operations described in 5.4.3.2.1 to 5.4.3.2.3 as required by subsection 4.4.

5.4.3.2.5 Attach a label to the weighing system in accordance with subsection 4.9.

#### **5.4.4 Uncertainty of calibration load**

##### **5.4.4.1 Uncertainty of calibration load - hydraulic cylinders with direct pressure measurement**

The hydraulic cylinders should be individually verified to traceable standards, with the uncertainty declared on their calibration certificate. The uncertainty for such systems varies widely, dependant on cylinder construction and means of pressure measurement. There will also be additional uncertainties due to the mechanical installation and when using a combination of cylinders and a common pressure measurement which is above the range verified for a single cylinder. The overall uncertainty of applied calibration load will need to be assessed on an individual basis but is unlikely to be lower than 0.5 %.

##### **5.4.4.2 Uncertainty of calibration load - hydraulic cylinders with load cells**

The load cells should be individually verified to traceable standards, with the uncertainty declared on their calibration certificate. There will also be additional uncertainties due to the mechanical installation. The overall uncertainty of applied calibration load will need to be assessed on an individual basis - it is likely to be in the range from 0.05 % to 1 %.

##### **5.4.4.3 Uncertainty of load application**

There may be many uncertainties additional to the above and these may be dominant. These uncertainties arise from the degree with which the calibration load is representative of the normal loads applied to the weighing structure, particularly with the parallel application approach. These uncertainties depend on the application and cannot be quantified in a general way, but consideration should be given to their relevance in each case.

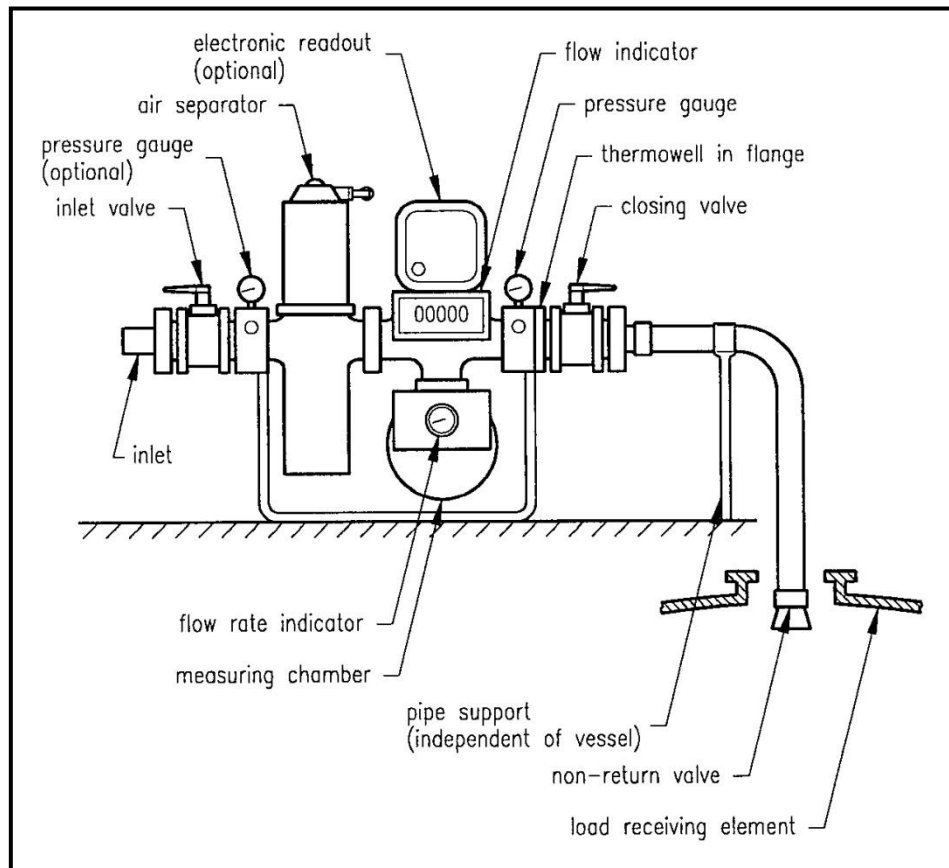
## **5.5 CALIBRATION PROCEDURE USING METERED FLOW**

### **5.5.1 Introduction**

This procedure may be used to calibrate vessels that can accept and retain a liquid. Calibration by metered flow within the context of this procedure focuses on the use of the positive displacement type of meter using a liquid process medium. Other flow meter types can be utilised having due regard to their measurement uncertainty. The process medium considered is water, but the procedure could be extended with care to other liquids, for applications where water is chemically unacceptable or the normal process medium has a higher density.

It is considered that this method is not practical and would not produce reliable data for decreasing load tests.





**Figure 10:** Calibration by flow meter - general arrangement

## 5.5.2 Specific requirements prior to calibration

- 5.5.2.1 Before commencing calibration, the vessel and all valves and connections should be checked for integrity.
- 5.5.2.2 A source of calibration process medium needs to be available and capable of delivery at the required flow rate and quantity.
- 5.5.2.3 The routing and control of the fluid should be such as to avoid additional or non-systematic errors.
- 5.5.2.4 Provision needs to exist to remove the process medium from the vessel after each loading procedure. Particular attention should be paid to the safe disposal of possibly contaminated calibration fluid.
- 5.5.2.5 The calibration of the flow meter should comply with the traceability requirements of subsection 4.3. Particular regard should be paid to confirmation intervals, especially where the highest performance is demanded. It is common practice to verify the calibration performance using a traceable standard calibration facility, such as a proving tank, immediately before and after a consecutive series of weighing system calibrations.

## 5.5.3 Calibration Procedure

- 5.5.3.1 Connect the flow meter to the vessel under test and introduce a quantity of fluid on a trial basis (the vessel can be usefully filled for this trial, serving to preload the weighing structure as well as checking that an adequate supply of fluid exists). During this trial, note the supply pressure, the flow rate, and the degree of variance.
- 5.5.3.2 Drain the vessel and set the flow meter to zero. Check that the weighing system output is stable and record its value.
- 5.5.3.3 Fill the vessel in steps up to the maximum operating capacity at a constant flow rate, consistent with the flow meter characteristics and the required weighing system performance.

5.5.3.4 Measurements of total liquid throughput and the corresponding weighing system output shall be recorded in accordance with subsection 4.4, having due regard to any turbulence. Each observation shall be made after terminating the liquid flow.

5.5.3.5 Record the flow rate, fluid temperature, and supply pressure between each calibration point, and report these values in the calibration certificate.

5.5.3.6 Drain the vessel and record the output of the weighing system. Where required by subsection 4.4, clauses 5.5.3.3 to 5.5.3.5 should be repeated.

5.5.3.7 Attach a label to the weighing system in accordance with subsection 4.9

#### 5.5.4 Conversion of flow meter reading to actual flow

The flow meter has a specified reading error which is dependent on flow rate and temperature. The formula given below may be used to compute the actual volume passed through the meter:

$$V_a = V_i \times F \times [ 1 + K_m ( T - 15 ) ]$$

where:  $V_a$  is the actual volume passed

$V_i$  is the indicated volume passed

$F$  is the meter factor at the observed flow rate, obtained from the meter calibration certificate

$K_m$  is the temperature coefficient of the meter obtained from the meter calibration certificate or manufacturer in  $^{\circ}\text{C}^{-1}$

$T$  is the temperature of the calibration fluid during test in  $^{\circ}\text{C}$

#### 5.5.5 Uncertainty of calibration load

The uncertainties considered here are the random elements present in the measurement of metered flow. The systematic uncertainties introduced if some compensating factors are not determined are dealt with in subsequent subsections.

The following table shows the source of error, the parameter used in establishing that error, and the possible effect on the measurement.

SOURCE OF ERROR	PARAMETER	EFFECT (% reading)	NOTE
Temperature error affecting meter correction	$15 \pm 0.5 \text{ }^{\circ}\text{C}$	$\pm 0.003 \%$	1
Uncertainty of flow meter reading	Each reported flow rate	$\pm 0.050 \%$	2
Pressure variation affecting flow rate	Max. 35 kPa (c. 5 psi)	$\pm 0.005 \%$	3

Combined uncertainty:  $\sqrt{(0.003^2 + 0.05^2 + 0.005^2)} = \pm 0.0503 \%$

Note 1: The flow meter calibration has to be corrected for temperature. The parameters chosen are examples for water at  $15^{\circ}\text{C}$  and are based on an estimated thermometer reading error combined with an estimate of the possible variation of fluid temperature between calibration points.

Note 2: Determination of water volume passed through a flow meter to high levels of uncertainty is an uncommon requirement. The UKAS-accredited TUV NEL can perform such calibrations to uncertainties of 0.05 %.

The above uncertainty of measurement assumes air free calibration medium.

Experimental work carried out at Warwickshire CC Trading Standards Laboratory, using a high performance positive displacement flow meter attached to a traceable proving tank, has shown that the uncertainties stated in this section can be achieved.

Note 3: Variations in water pressure will affect the flow rate. The pressure variation stated is the suggested maximum variation of test fluid supply pressure which should be permitted during the calibration.

### 5.5.6 Correction for density

The conversion to weight of the observed readings of volume, obtained from the flow meter, requires a knowledge of the density of the calibration medium.

The density of calibration fluid is sensitive to temperature. There will be an additional random uncertainty when correcting for temperature due to the uncertainty of fluid temperature determination. Using the parameters as in 5.5.5 for water at 15 °C this factor leads to an additional uncertainty of  $\pm 0.0075\%$ . The uncertainty for other fluids and at other reference temperatures will not be dissimilar.

5.5.6.1 The density of air-free water under various conditions is well documented, but where an alternative calibration fluid is used, it is probable that its density will need to be determined at the time of calibration.

Density determination under site conditions is normally performed using a float hydrometer. These are commonly available and generally calibrated in small spans of density covering the range from  $700 \text{ kg}\cdot\text{m}^{-3}$  to  $2000 \text{ kg}\cdot\text{m}^{-3}$ , adequate for most applications. The uncertainty of measurement of such a device is typically  $0.01\%$  - the actual value will be stated on the calibration certificate for the hydrometer.

The uncertainty figure for calibrations where density is determined by float hydrometer is increased from that calculated in 5.5.4.

The combined uncertainty:  $\sqrt{(0.003^2 + 0.05^2 + 0.005^2 + 0.0075^2 + 0.01^2)} = 0.052\%$

5.5.6.2 The physical properties of water are very well researched and documented in reference literature. Table 2 details the relationship between the density  $\rho$  of pure air-free water, at a pressure of 7 kPa, and temperature  $T$ .

**Table 2:** Density of pure air-free water as a function of temperature

$T / ^\circ\text{C}$	$\rho / \text{kg}\cdot\text{m}^{-3}$	$T / ^\circ\text{C}$	$\rho / \text{kg}\cdot\text{m}^{-3}$	$T / ^\circ\text{C}$	$\rho / \text{kg}\cdot\text{m}^{-3}$	$T / ^\circ\text{C}$	$\rho / \text{kg}\cdot\text{m}^{-3}$
0	999.839 6	0.5	999.871 3	1	999.898 5	1.5	999.921 4
2	999.939 9	2.5	999.954 1	3	999.964 2	3.5	999.970 1
4	999.972 0	4.5	999.969 8	5	999.963 7	5.5	999.953 7
6	999.939 9	6.5	999.922 4	7	999.901 1	7.5	999.876 2
8	999.847 7	8.5	999.815 7	9	999.780 1	9.5	999.741 1
10	999.698 7	10.5	999.653 0	11	999.603 9	11.5	999.551 6
12	999.496 1	12.5	999.437 4	13	999.375 6	13.5	999.310 6
14	999.242 7	14.5	999.171 7	15	999.097 7	15.5	999.020 8
16	998.941 0	16.5	998.858 3	17	998.772 8	17.5	998.684 5
18	998.593 4	18.5	998.499 5	19	998.403 0	19.5	998.303 7
20	998.201 9	20.5	998.097 3	21	997.990 2	21.5	997.880 5
22	997.768 3	22.5	997.653 6	23	997.536 3	23.5	997.416 6
24	997.294 4	24.5	997.169 9	25	997.042 9	25.5	996.913 5
26	996.781 8	26.5	996.647 7	27	996.511 3	27.5	996.372 6
28	996.231 6	28.5	996.088 4	29	995.943 0	29.5	995.795 3
30	995.645 4						

Source: *Physikalisch Technische Bundesanstalt*, Braunschweig, Germany

5.5.6.3 The density of mains water will be higher than pure water by an amount which varies according to the water source. The variations throughout the UK however are quite small;  $0.013\%$  between very hard and very soft water areas.

If correction for the water source is neglected and the table below used for density correction data the uncertainty figure calculated in 5.5.4 becomes,

$\sqrt{(0.003^2 + 0.05^2 + 0.005^2 + 0.013^2)} = 0.052\%$

5.5.6.4 Table 3 details the relationship between the density  $\rho$  of air-free mains water, at a pressure of 7 kPa, and temperature  $T$ .

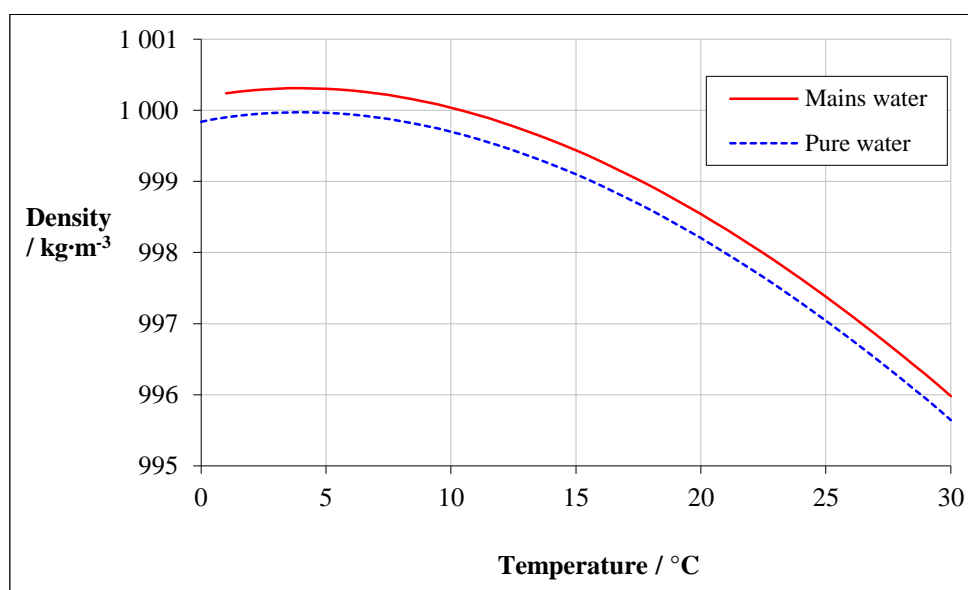
**Table 3:** Density of air-free mains water as a function of temperature

$T / ^\circ\text{C}$	$\rho / \text{kg}\cdot\text{m}^{-3}$	$T / ^\circ\text{C}$	$\rho / \text{kg}\cdot\text{m}^{-3}$	$T / ^\circ\text{C}$	$\rho / \text{kg}\cdot\text{m}^{-3}$	$T / ^\circ\text{C}$	$\rho / \text{kg}\cdot\text{m}^{-3}$
1	1 000.236 2	1.5	1 000.259 1	2	1 000.277 6	2.5	1 000.291 8
3	1 000.301 9	3.5	1 000.307 8	4	1 000.309 7	4.5	1 000.307 5
5	1 000.301 4	5.5	1 000.291 4	6	1 000.277 6	6.5	1 000.260 1
7	1 000.238 8	7.5	1 000.213 9	8	1 000.185 4	8.5	1 000.153 4
9	1 000.117 8	9.5	1 000.078 8	10	1 000.036 4	10.5	999.990 7
11	999.941 6	11.5	999.889 3	12	999.833 8	12.5	999.775 1
13	999.713 3	13.5	999.648 3	14	999.580 4	14.5	999.509 4
15	999.435 4	15.5	999.358 5	16	999.278 7	16.5	999.196 0
17	999.110 5	17.5	999.022 2	18	998.931 1	18.5	998.837 2
19	998.740 7	19.5	998.641 4	20	998.539 6	20.5	998.435 0
21	998.327 9	21.5	998.218 2	22	998.106 0	22.5	997.991 3
23	997.874 0	23.5	997.754 3	24	997.632 1	24.5	997.507 6
25	997.380 6	25.5	997.251 2	26	997.119 5	26.5	996.985 4
27	996.849 0	27.5	996.710 3	28	996.569 3	28.5	996.426 1
29	996.280 7	29.5	996.133 0	30	995.983 1		

Source: *Physikalisch Technische Bundesanstalt*, Braunschweig, Germany

5.5.6.5 It follows that, should the temperature of calibration mains water not be taken and the density assumed as  $1\,000\text{ kg}\cdot\text{m}^{-3}$ , an additional error will be introduced. For actual water temperatures of  $5\text{ }^\circ\text{C}$  and  $15\text{ }^\circ\text{C}$  (N.B. according to the Water Research Centre, the temperature of rising mains water in the UK typically varies between  $5\text{ }^\circ\text{C}$  and  $15\text{ }^\circ\text{C}$ ), these errors will be  $0.03\%$  and  $-0.06\%$  respectively. For an actual water temperature of  $10\text{ }^\circ\text{C}$ , this error will be less than  $0.01\%$ .

Figure 11 illustrates the relationship between temperature and density for both pure and mains water.



**Figure 11:** Density of water as a function of temperature

## 5.6 CALIBRATION PROCEDURE USING PROVING TANKS

### 5.6.1 Introduction

This procedure may be used to calibrate systems that can accept and retain a liquid. Calibration by proving tanks within the context of this procedure is restricted to the use of traceable capacity measures using water as the calibration medium.

The method is considered practical for increasing load calibration only and, while portable traceable measures with capacities above 100 litres are rare, multiple use of a measure will enable larger vessels to be calibrated.

### 5.6.2 Specific requirements prior to calibration

5.6.2.1 Before commencing calibration, check the system and all valves and connections for integrity.

5.6.2.2 A source of calibration water needs to be available in the required quantities and at a delivery flow rate appropriate to the size of the proving tank.

5.6.2.3 The proving tank should be able to be sited such that its contents can be discharged by gravity directly and unencumbered into the vessel under calibration.

5.6.2.4 The proving tank should be sited at its operating location and primed by filling and emptying once to establish a standard drainage rate.

5.6.2.5 Provision should exist to remove the water from the vessel after each loading procedure.

### 5.6.3 Calibration procedure

5.6.3.1 With zero calibration load, check that the weighing system output is stable and record the output.

5.6.3.2 Fill the proving tank to its top datum and record the temperature of the water.

5.6.3.3 Discharge the contents of the proving tank into the vessel under test for the standard drainage time appearing on its calibration certificate.

5.6.3.4 Record the output of the weighing system in accordance with subsection 4.4, having due regard to any turbulence.

5.6.3.5 Repeat steps 5.6.3.2 to 5.6.3.4 until the maximum operating capacity of the weighing system is reached.

5.6.3.6 Where required by subsection 4.4, repeat steps 5.6.3.1 to 5.6.3.5, having due regard for any turbulence.

5.6.3.7 Attach a label to the weighing system in accordance with subsection 4.9.

### 5.6.4 Uncertainty of calibration load

The uncertainties considered here are the random elements present in the measurement of the volume of water discharged from a proving tank and its conversion to weight. The systematic uncertainty introduced if the density of the proving tank contents is not determined is dealt with in the relevant section below.

SOURCE OF ERROR	PARAMETERS	EFFECT / % reading	NOTE
Temperature error affecting density	15 ± 1 °C	+0.015 0	1
Temperature error affecting expansion of proving tank	15 ± 1 °C	-0.004 4	2
Proving tank volume uncertainty		±0.010 0	3

$$\text{Combined uncertainty} = \sqrt{(0.01)^2 + (0.015 - 0.0044)^2} = 0.015 \%$$

Note 1: The density of calibration water is sensitive to temperature. This error is calculated as typical of the change in density that will occur due to the uncertainty of fluid temperature determination. The parameters chosen are examples for water at 15 °C and are based on an estimated thermometer reading error combined with an estimate of the possible variation of actual fluid temperature due to uneven mixing of water in the tank. The uncertainty at other reference temperatures will not be dissimilar.

Note 2: The proving tank volume changes with temperature, a correction factor is used to compensate for this change. The parameters chosen are an example for water at 15 °C and are based on an estimated thermometer reading error combined with an estimate of the variation of actual fluid temperature and its effect on the tank dimensions throughout its volume.

Note 3: The proving tank volume uncertainty is based on the uncertainty of calibration load for the relevant test method for volume determination.

### 5.6.5 Correction for density

The conversion of the proving tank volume to weight requires a knowledge of the density of the calibration water. The density of pure mains water is presented in clause 5.5.6.2.

5.6.5.1 If mains water is used, its source neglected, and the table in 5.5.6.3 is used for temperature correction data, the uncertainty of calibration load calculated in clause 5.6.4 becomes:

$$\sqrt{(0.01^2 + (0.015 - 0.0044)^2 + 0.013^2)} = 0.020 \%$$

## **5.7 CALIBRATION PROCEDURE USING METHODS REMOTE TO THE OPERATING INSTALLATION**

### **5.7.1 Introduction**

A weighing system may be calibrated out of its normal working installation where it is deemed the effect of the influences associated with the weighing structure (ref. section A1), are negligible or acceptable in its operation. This method is also suitable where a fixed weighing structure is not part of the weighing system, such as in portable aircraft weighing systems.

This type of calibration is normally carried out in a laboratory where a force standard machine, traceable to national standards, is used to apply loads to the load cells.

### **5.7.2 Specific requirements prior to calibration**

The mechanical arrangement of the load cell(s), i.e. the fittings used and load distribution on the cells, should be similar, as far as practicable, to that of the normal installation. If fittings are not provided, the calibration authority may, at their discretion, provide suitable fittings. In such cases, this information should be included in the calibration certificate.

Special attention needs to be paid to the actual load distribution on the load cells if the calibration is carried out on a multiple load cell assembly placed within a force standard machine.

The associated weighing instrumentation configuration should be the same as that of the normal operating installation. The junction box wiring and lengths of cables used should correspond to the actual operating installation.

It is recommended that the temperature of the laboratory environment be monitored and reported in the calibration certificate. The method of loading should be in accordance with subsection 4.4.

### **5.7.3 Calibration procedure**

5.7.3.1 Apply a load to the load cell(s) so that the weighing system output reads zero (this is equal to the zero live load). Record the load applied and the system output.

5.7.3.2 Apply a load equal to the sum of the zero live load and maximum operating capacity, and record this output.

5.7.3.3 Repeat steps 5.7.3.1 and 5.7.3.2 until stable readings are obtained.

5.7.3.4 Compute the difference between the outputs recorded in steps 5.7.3.2 and 5.7.3.1. This represents the output for the weighing range.

5.7.3.5 Apply a load equal to or near as practicable to 20 % of weighing range above the zero live load. Record the system output.

5.7.3.6 Repeat 5.7.3.5 for the loads substantially equal to 40 %, 60 %, 80 % and 100 % of the weighing range. Record the corresponding system outputs and then return to a load equal to the zero live load.

5.7.3.7 Repeat 5.7.3.5 and 5.7.3.6 twice to give three series of readings.

5.7.3.8 Remove the load cells from the force standard machine.

5.7.3.9 Attach a label to the system in accordance with subsection 4.9.

### **5.7.4 Uncertainty of calibration load**

The uncertainty of the calibration load is the same as the uncertainty of measurement specified for the force standard machine used to calibrate the weighing system. See [EURAMET/cg-04/v.01](#) for details of force standard machines.

## 6 QUALITY OF SERVICE

The testing and calibration operations should ideally be carried out by organisations operating in accordance with the requirements of [BS EN ISO/IEC 17025](#). In the United Kingdom, third-party recognition of the competence of the calibration authority is demonstrated by UKAS accreditation.

However, as no organisation is presently accredited by UKAS for the site calibration operations described in this Code of Practice, it is proposed that the calibration authority establishes its competence by obtaining certification to [BS EN ISO 9001](#) and having the appropriate Company Operating Procedures to control the site calibration operations.

[BS EN ISO 10012](#) includes requirements and guidance for the implementation of measurement management systems, and may be useful in improving measurement activities.

# ANNEX I

## A1. GENERAL CONSIDERATIONS

### A1.1 INFLUENCE QUANTITIES

Prior to the commencement of calibration, it is recommended that the weighing system should be visually inspected for integrity and suitability. Where possible and appropriate this inspection may include the mechanical condition of the vessel such as clearances and any permanent attachments linking the weighing structure to the load bearing structure. The condition of any junction boxes and signal processing components should also be assessed.

Particular consideration should be given to the factors listed below. Where possible these should be quantified or otherwise allowed for or eliminated. Some of the factors may not be present during the calibration but may affect the system when it is in normal operation. Where relevant, the influence quantities may be reported in the calibration certificate.

#### A1.1.1 Pressure/Vacuum

- Pressure variations within a weighed vessel may cause significant changes in weighing system output. This may be due to forces induced in flexible pipe couplings, restrictions in breather systems, or recorded changes in the mass of gaseous content.

#### A1.1.2 Temperature

- Temperature changes of the components in the measuring chain due to general ambient variations or local heating from auxiliary equipment can affect weighing system output.
- Convection currents created by heated jackets or adjacent heat generating equipment can give rise to thermal viscous drag causing changes in weighing system output.
- Weight changes of the contents of any heat transfer system attached to the weighing system must be taken into consideration.
- Thermal expansion or contraction of the weighing structure or mechanical attachments will affect weighing system output.
- Sunlight can cause uneven temperature changes to weighing system components leading to error.

#### A1.1.3 Structural effects

- Vibration from agitators, vibrators, or other ancillary plant items can cause fluctuating or incorrect outputs.
- Deflection or settlement of the load bearing structure can cause measurement errors.
- Worn or weak supports such as knife edges can produce an inclined load or movement of the point of support from the design position leading to error.
- The output of a weighing system sharing a common load bearing structure with other plant may be affected by interaction.

#### A1.1.4 Method of loading

- Shock loading during operational use can cause displacement of weighing system components which may not be apparent during calibration.
- Impact of a load can cause the weighing system to output a higher value than the static figure.
- Turbulence of the contents of a load receiving element may cause fluctuations in output.
- Consideration should be given to the distribution of the calibration load when this differs from the distribution of the operational load.

#### A1.1.5 Climatic and local effects

- Ambient temperature effects are dealt with in A1.1.2.
- Ambient pressure changes can affect the output of pneumatic systems and may also affect electrical systems employing load cells which are not barometrically compensated.
- Environmental elements such as snow can form an additional and variable weight.
- Wind loads may affect weighing system output.
- The possibility of local interference from animal or human causes should be considered during calibration.



### A1.1.6 Mechanical effects

- Any restriction of movement of the weighing structure will modify the performance of the weighing system. This should be considered when inspecting tie bars and check rods, flexible or rigid pipe connections, couplings, tension wires, walkways, electrical or pneumatic connections, and safety measures such as earthing straps.
- Friction between the weighing structure and load bearing structure, or in corroded or dirty knife edge supports, will lead to random errors.
- Interaction between the material in the load receiving element and the load bearing or any other external structure can cause errors. This is most likely to occur at or near maximum capacity.

### A1.1.7 Radiation and other electrical effects

- The weighing system may be affected by high levels of RFI and EMI. A common source of such problems is radio transmitters used in conjunction with the calibration procedures.

## A1.2 PORTABLE WEIGHING SYSTEMS

All load cell weighing systems measure forces exerted by a mass which they support. This force is dependent on the value of the acceleration of free fall,  $g$ , at the location of use, see Annex A7.

Consideration should be given to this effect, and where the variation in the weighing system output due to the change in the  $g$  value is considered unacceptable, the weighing system should be calibrated at the location of use. Some systems allow numerical correction of this effect through their software.

### A1.3 AIR BUOYANCY EFFECT

The air surrounding a mass exerts an air buoyancy force in the opposite direction to the downward force that the weighing system measures, depending on the volume of air displaced by the mass.

Consideration should be given to the possible effect of air buoyancy on the calibration of a weighing system when one material is used for calibration and another, of different density, is used during normal weighing operations.

A typical example is that an error of approximately 0.1 % is introduced when cast iron weights are used to calibrate a system normally weighing material of similar density to water. This is due to the fact that  $1 \text{ m}^3$  of cast iron weighing 8 000 kg experiences an upthrust of approximately 12 N, whereas the same weight of water occupies  $8 \text{ m}^3$  and experiences an upthrust of approximately 96 N.

Air buoyancy correction may be made by using the following equation,

$$W_{\text{true}} = W_{\text{ind}} [ ( 1 - \rho_a / \rho_s ) / ( 1 - \rho_a / \rho_m ) ]$$

where,

$W_{\text{true}}$  is the true weight in the load receiving element

$W_{\text{ind}}$  is the weight indicated by the weighing system

$\rho_a$  is the density of the air

$\rho_s$  is the density of the material used to calibrate the weighing system

$\rho_m$  is the density of the weighed object

Example: A petroleum product having a density of  $800 \text{ kg}\cdot\text{m}^{-3}$  is going to be weighed in air of typical density ( $1.2 \text{ kg}\cdot\text{m}^{-3}$ ) on a weighing system which is calibrated by the use of standard weights of density  $8\,000 \text{ kg}\cdot\text{m}^{-3}$ . When the load receiving element is filled with the product so that the indicator reads 1 000 kg, the true weight in the load receiving element can be obtained from:

$$\begin{aligned} W_{\text{true}} &= 1\,000 [ ( 1 - 1.2 / 8\,000 ) / ( 1 - 1.2 / 800 ) ] \\ &= 1\,000 \times 1.001\,35 \\ &= 1\,001.35 \text{ kg} \end{aligned}$$

Therefore the actual weight in the vessel is 0.135 % more than indicated, since more material is needed to overcome the buoyancy effect. This value would be reduced if the density of the standard weight material were closer to that of the product.

#### **A1.4 WEIGHING SYSTEM INCORPORATING DUMMY LOAD CELLS OR PIVOTS**

The output of a weighing system incorporating dummy load cells is sensitive to the changes of the centre of gravity of the load receiving element. Where possible and practicable, it is recommended that the calibration of such systems is carried out with self-levelling materials.

Where this is not possible, a method of calibration should be selected during which the centre of gravity remains in the same position as that of the weighing system in its normal operation.

#### **A1.5 INFLUENCE OF ZERO TRACKING**

It is recommended that any zero tracking system be inhibited during calibration.

## ANNEX II

### A2. CALIBRATION OF WEIGHING SYSTEM COMPONENTS

The methods detailed below are mainly for establishing the operational integrity of the components of the weighing system and do not take into account the effects of the mechanical influences which may be present in the system. These methods are unlikely to comply with the requirements of BS EN ISO 9000 series entitled 'Quality management and quality assurance standards'. It is recommended that the user considers the suitability of these methods prior to implementation.

#### A2.1 USE OF LOAD CELL SIMULATOR

##### A2.1.1 Introduction

This method should only be used where it is acceptable to omit the error contributions from the load cells and the influences of their associated mechanical structure. Certain load cell simulators may not be capable of simulating the electrical loading on the weighing instrumentation in multiple load cell installations.

This method is only applicable to weighing systems utilising strain gauge type analogue load cells.

##### A2.1.2 Specific requirements

It is important to ensure that the disconnection of the load cells has no adverse effect on the weighing system.

Attention should be given to the polarity of the signal in connecting the simulator with reference to tension or compression load application on the load cells.

The simulator should be allowed to stabilise before the commencement of the calibration. Cognisance should be taken of any guidance and recommendations from the manufacturer of the simulator in deciding this stabilisation period.

##### A2.1.3 Procedure

A2.1.3.1 Ensure that there is no load on the load receiving element, and record the weighing system output.

A2.1.3.2 Remove all existing load cell connections in the junction box.

A2.1.3.3 Connect the load cell simulator in place of the load cell(s). Allow the simulator to stabilise.

A2.1.3.4 Adjust the simulator so that the weighing system output indicates the value recorded in A2.1.3.1. Record the setting or output of the simulator.

A2.1.3.5 Adjust the simulator so that the weighing system output indicates the maximum operating capacity. Record the setting or output of the simulator.

A2.1.3.6 Repeat the steps in A2.1.3.4 and A2.1.3.5 until stable readings are obtained for minimum and maximum operating capacity.

A2.1.3.7 Set the simulator to represent 20 % of the maximum operating capacity and record the weighing system output and the simulator setting or output.

A2.1.3.8 Repeat A2.1.3.7 at 20 % intervals up to the maximum operating capacity and record the weighing system output and the corresponding load cell simulator setting or output.

A2.1.3.9 Repeat steps A2.1.3.7 and A2.1.3.8 twice more to obtain three sets of readings.

A2.1.3.10 Remove the load cell simulator and replace the load cell connections in the junction box. Allow the system to stabilise. Record the output which should read as noted in A2.1.3.1.

A2.1.3.11 Attach a label to the weighing system in accordance with subsection 4.9.

##### A2.1.4 Guidance on using a load cell simulator

Most commercially available load cell simulators are based on the Wheatstone bridge principle. They may incorporate a network of resistors or strain gauges. The output signal is usually adjusted by the use of a thumb wheel switch in millivolt per volt units or the output may be in millivolt units and adjusted by a potentiometer. These units generally simulate a single load cell with the appropriate input and output resistance, typically 350  $\Omega$ .

It is recommended that, if the simulator used is not capable of simulating the correct number of load cells in the installation, a suitable resistor network should be used to achieve the required loading.

#### **A2.1.5 Uncertainty of simulated load**

It is not possible to estimate, with reasonable confidence, an uncertainty figure for the complete weighing system calibrated using this method. It is recommended that the manufacturer's stated accuracy or uncertainty for the load cell simulator should be used as a basis to estimate the uncertainty of the signal applied to the weighing system.

### **A2.2 USE OF MILLIVOLT SOURCE**

#### **A2.2.1 Introduction**

This method is only applicable to weighing systems utilising strain gauge type analogue load cells.

This method should only be used where it is acceptable to ignore the error contributions from the load cells and the influences of their associated mechanical structure. The use of a millivolt source is considered only appropriate in weighing systems where dc excitation voltage is used.

#### **A2.2.2 Specific requirements**

It is important to ensure that the disconnection of the signal wires of the load cells has no adverse effect on the weighing system. Attention should be paid especially to those systems utilising six wire sense circuitry.

Attention should be given to the polarity of the signal in connecting the millivolt source with reference to tension or compression load application on the load cells. The millivolt simulator should be allowed to stabilise before the commencement of the calibration. Cognisance should be taken of the guidance and recommendations from the manufacturers of the millivolt source in deciding this stabilisation period.

#### **A2.2.3 Procedure**

A2.2.3.1 Ensure that there is no load on the load receiving element, and record the weighing system output.

A2.2.3.2 Remove only the load cell signal leads in the junction box.

A2.2.3.3 Connect the millivolt source in place of the load cell signal leads. Allow the millivolt source to stabilise.

A2.2.3.4 Adjust the millivolt source so that the weighing system output indicates the output recorded in A2.2.3.1. Record the output of the millivolt source.

A2.2.3.5 Adjust the millivolt source so that the weighing system output indicates the maximum operating capacity. Record the output of the millivolt source.

A2.2.3.6 Set the millivolt source to represent 20 % of the maximum operating capacity and record the weighing system output and millivolt source output.

A2.2.3.7 Repeat the step A2.2.3.6 at 20 % intervals up to the maximum operating capacity and record the weighing system output and the corresponding millivolt source output.

A2.2.3.8 Repeat steps A2.2.3.6 and A2.2.3.7 where required by subsection 4.4.

A2.2.3.9 Remove the millivolt source and replace the load cell signal leads in the junction box. Allow the system to stabilise. The weighing system output should read as noted in A2.2.3.1.

A2.2.3.10 Attach a label to the weighing system in accordance with subsection 4.9.

#### **A2.2.4 Uncertainty of simulated load**

It is not possible to estimate, with reasonable confidence, an uncertainty figure for the complete weighing system calibrated using this method. It is recommended that the manufacturer's stated accuracy or uncertainty of measurement for the millivolt source should be used as a basis to estimate the uncertainty of the signal applied to the weighing system.

## **A2.3 USE OF SHUNT RESISTORS**

### **A2.3.1 Introduction**

This method should only be used where it is acceptable to ignore the error contributions from inappropriate mechanical application of load to the load cells and the influence of the associated mechanical structure.

The procedure depends on manufacturer's data being available, defining the output of a particular load cell when a resistor of specified value is connected in parallel (shunted), to one branch of the strain gauge bridge. The output will be stated as equal to that which would have been produced by a force of equal magnitude.

The output data is related to the resistance of the load cell and its connecting cables. The connections may differ from those given by the manufacturer which appear on the load cell calibration certificate. Any modifications must be taken into account when evaluating data.

Normally one shunt calibration resistor is used.

The information obtained can also be used to perform subsequent spot checks to confirm the weighing system performance.

### **A2.3.2 Specific requirements prior to calibration**

Cognisance should be taken of the guidance and recommendations provided by the load cell manufacturer for any shunt calibration data that may be provided for the system.

### **A2.3.3 Procedure**

A2.3.3.1 Ensure that there is no load on the load receiving element, and record the weighing system output.

A2.3.3.2 Connect the shunt calibration resistor across one arm of the strain gauge bridge in the manner recommended by the manufacturer (this may be achieved by push button actuation of the shunt calibration facility in proprietary weighing instrumentation).

A2.3.3.3 Record the weighing system output in accordance with subsection 4.4.

A2.3.3.4 Repeat steps A2.3.3.1 to A2.3.3.3 twice more to obtain three sets of readings.

A2.3.3.5 Attach a label to the weighing system in accordance with subsection 4.9.

### **A2.3.4 Guidance on using shunt calibration resistors**

#### **A2.3.4.1 Uncertainty of simulated load**

It is not possible to estimate, with reasonable confidence, an uncertainty figure for the complete weighing system calibrated using this method. It is recommended that the manufacturer's stated uncertainty for the shunt calibration data be used as a basis to estimate the uncertainty of the signal applied to the weighing system.

#### **A2.3.4.2 Load cell cable**

The shunt calibration figure provided by the manufacturer will relate to a transducer with its original length (or a specified length) of connection cable intact. This cable should not normally be cut or extended without prior reference to the manufacturer.

The shunt calibration figures will also be modified in multiple load cell systems and where additional interconnecting cable is used.

## **A2.4 USE OF THEORETICAL CALCULATIONS**

### **A2.4.1 Introduction**

This method may only be used where it is acceptable to ignore the error contributions from inappropriate mechanical application of load to the load cells and the influence of the associated mechanical structure.

The viability of this method depends on the availability of a full certificate of performance (see [BS 8422](#)) and calibration certificate for the individual load cells, the associated weighing instrumentation, and other elements of the measuring chain as appropriate.

The data presented in the calibration certificate for the weighing system is obtained by combining data given in individual calibration certificates of the load cells and the weighing instrumentation at selected load points. This may involve interpolation of data in order to obtain common loading points on the load cells and the weighing instrumentation. The interpolation of data is acceptable, but extrapolation of data should be avoided.

#### **A2.4.2 Specific requirements**

It is important that the operating conditions of the weighing system shall be established, detailing all the relevant parameters such as dead load, weighing range, gross weight, and maximum operating capacity. The performance certificates or calibration certificates for the load cells and weighing instrumentation should be available and comply with the traceability requirements given in subsection 4.3.

In the case of multiple load cell weighing systems, the distribution of load on load cells shall be considered.

#### **A2.4.3 Procedure**

A2.4.3.1 Select not fewer than five substantially equally-spaced loads covering the weighing range, to obtain the calibration data.

A2.4.3.2 Compute the combined outputs of the load cells at each of these selected loads for increasing and, if required, decreasing loads.

A2.4.3.3 Compute the weighing instrumentation output for the combined load cell outputs.

A2.4.3.4 Report the selected loads and the corresponding computed weighing instrumentation output in the calibration certificate.

A2.4.3.5 Attach a label to the weighing system in accordance with subsection 4.9.

#### **A2.4.4 Guidance on the method of combining calibration data**

In a typical weighing system a number of load cells are connected in parallel in a junction box or at the input of the weighing instrumentation. The resultant combined signal at this point may be expressed by the following equation,

$$e_o = \frac{\sum_{i=1}^n \frac{e_i}{R_i}}{\sum_{i=1}^n \frac{1}{R_i}}$$

where,

- $e_o$  is the combined open circuit output
- $e_i$  is the output voltage of the individual load cell
- $R_i$  is the output resistance of the individual load cell
- $n$  is the number of load cells connected in parallel

The above equation may be used to obtain the combined output for several loads.

#### **A2.4.5 Uncertainty of calibration load**

Uncertainty of combined calibration load is the root mean square of the uncertainty of the load applied to the individual load cells when calibrated.

## **A2.5 REVALIDATION OF LEVER SYSTEMS**

### **A2.5.1 Introduction**

This method may be used as a revalidation check of a lever operated weighing system which incorporates a single load cell and where it is acceptable to disregard the error contributions from the mechanical construction of the weighing system.

The procedure depends on the provision, usually by the manufacturer, of a defined location and method of applying a known test load to the lever system or directly to the load cell. It is important that the load is applied in the same direction as the normal operating loads.

The test load may be standard weights, reference weights, or a combination of these.

### **A2.5.2 Specific requirements**

Cognisance should be taken of guidance and recommendations provided by the weighing system manufacturer for any data which may be provided on the operation of levers or method of applying load to the associated load cell.

There should be a clearly defined location for the application of test load, and the value of this test load needs to have been specified.

The test load and, if relevant, its associated hangers, platforms etc., should comply with the traceability requirements given in subsection 4.3.

### **A2.5.3 Procedure**

A2.5.3.1 Ensure that there is no load on the load receiving element and record the weighing system output.

A2.5.3.2 Apply the test load to the specified location and record the weighing system output in accordance with subsection 4.4.

A2.5.3.3 Remove the load and repeat A2.5.3.1 and A2.5.3.2 twice more to obtain three sets of readings.

A2.5.3.4 Attach a label to the weighing system in accordance with subsection 4.9.

### **A2.5.4 Uncertainty of applied load**

The uncertainty of standard weights should be calculated on the basis given in 5.1.4.

The uncertainty of reference weights should be calculated on the basis given in 5.2.4.

There may be additional uncertainties due to perturbation of the load measured by the load cell, caused by the mechanics of the lever system, or inherent in the application of this method. Cognisance should be taken of the manufacturer's information in this respect.

## ANNEX III

### A3. PROCESSING OF CALIBRATION DATA

For the purpose of computing data in this section, the term ‘weighing system output’ is defined as the value of the difference between the system output at the calibration load and the system output at zero live load of each calibration test.

When quoting quantities such as non-linearity and combined error, the associated method of determination should also be specified.

#### A3.1 Calculation of non-linearity using the “best straight line through zero” (BSLZ) method

A3.1.1 Calculate, where applicable, the average value of weighing system output for increasing loads only, for each calibration load applied.

A3.1.2 Compute a ‘best fit’ straight line passing through zero, relating the average weighing system output to the load applied, by the method of least squares using the expression;

$$m = \frac{\sum (L_i \times R_i)}{\sum L_i^2}$$

where,

$m$  is the slope of the BSLZ

$L_i$  is the load applied

$R_i$  is the weighing system output corresponding to load  $L_i$

A3.1.3 For each calibration load, calculate the difference between the average weighing system output and the value computed from the BSLZ. The non-linearity at this load is this difference, expressed as a percentage of span.

#### A3.2 Calculation of non-linearity using the “terminal line” method

A3.2.1 Calculate, where applicable, the average value of weighing system output for increasing loads only, for each calibration load applied.

A3.2.2 For each calibration load applied, compute the weighing system output from the terminal line.

A3.2.3 For each calibration load, calculate the difference between the average weighing system output and the value computed from the terminal line. The non-linearity at this load is this difference, expressed as a percentage of span.

#### A3.3 Calculation of non-linearity (decreasing) using the BSLZ method

This is an identical calculation to that in A3.1 but using data for decreasing loads only.

#### A3.4 Calculation of non-linearity (decreasing) using the terminal line method

This is an identical calculation to that in A3.2 but using data for decreasing loads only.

#### A3.5 Calculation of hysteresis

A3.5.1 Calculate, where applicable, the average value of weighing system output for each increasing and decreasing calibration load applied.

A3.5.2 For each calibration load, calculate the difference between the weighing system outputs for increasing load and decreasing load. The hysteresis at this load is this difference, expressed as a percentage of span.

#### A3.6 Calculation of combined error, using the BSLZ method

The combined error here includes repeatability.



A3.6.1 Calculate, where applicable, the average value of weighing system output for each increasing and decreasing calibration load applied.

A3.6.2 Compute a 'best fit' straight line passing through zero, relating the weighing system output to the load applied, by the method of least squares using the expression given in A3.1.2.

A3.6.3 For each calibration load, both increasing and decreasing, calculate the difference between the actual weighing system output and the value computed from the BSLZ. The combined error is the maximum such difference, expressed as a percentage of span.

### **A3.7 Calculation of combined error, using the terminal line method**

The combined error here includes repeatability.

A3.7.1 Calculate, where applicable, the average value of weighing system output for each calibration load applied.

A3.7.2 For each calibration load, both increasing and decreasing, calculate the weighing system output corresponding to a straight line passing through zero load and maximum load applied.

A3.7.3 For each calibration load, both increasing and decreasing, calculate the difference between the actual weighing system output and the value computed from the straight line. The combined error is the maximum such difference, expressed as a percentage of span.

### **A3.8 Calculation of repeatability**

A3.8.1 Calculate the spread (maximum – minimum) between the three weighing system outputs taken at each repeated calibration load for increasing and, if measured, decreasing loads.

A3.8.2 The repeatability at this load is this spread, expressed as a percentage of span.

## ANNEX IV

### A4. TEST PROCEDURES AND PROCESSING OF TEST DATA

These test procedures may also have relevance as additional tests that can be performed in conjunction with calibration procedures in this Code of Practice.

#### A4.1 Determination of eccentric loading effects

A4.1.1 The weighing structure may be loaded during normal operations or during calibration in an asymmetric way relative to the geometry of the load cell supports. The output of the weighing system may be in error due to an imbalance of contribution to the total output made by each load cell or other physical causes. The magnitude of these errors can be determined by the following test procedure.

A4.1.2 Divide the loading area into the same number of substantially equal segments as the weigh structure has supports. The segments should be as near as practicable symmetric to the support.

A4.1.3 When determining the position for the placement of test loads within a segment (where such flexibility is available), due consideration should be given to replicate, as far as possible, the normal operational load distribution (as stated in subsection 4.4.1.3). This ideally means that the test load should be placed at the position where the estimated centre of mass of the operational load would lie. Test loads (especially standard calibration weights) frequently have much higher densities than operational loads, and consequently may be physically placed 'further outboard' than the operational loads, thus accentuating eccentricity errors.

A4.1.4 With zero calibration load, check that the weighing system output is stable and then record the output.

A4.1.5 Place a test load of value, as near as possible, to that shown below, within each segment, in accordance with subsection 4.4 and record the output.

Number of supports ( $n$ )	Test load
	Maximum operating capacity (Note 1)
1	1/3 (Note 2)
2	1/3
3	1/3
4	1/3
$n > 4$	1/( $n-1$ )

Note 1: A load receiving element subject to minimal off-centre loading during normal operation may be tested with a test load of 1/10 of the maximum operating capacity.

Note 2: A load receiving element supported by a single load cell should be tested by placing the test load at selected positions on the load receptor. The locations chosen should be recorded.

A4.1.6 Repeat steps A4.1.4 and A4.1.5 twice more to give three series of readings.

#### A4.2 Calculation of eccentric loading effects

A4.2.1 Calculate the average value of weighing system output for each eccentric load applied.

A4.2.2 Calculate the overall average value of weighing system output for all the eccentric loads applied.

A4.2.3 Compute the maximum difference between the average value for each eccentric load and the overall average and express this difference as a percentage of the overall average.

#### A4.3 Determination of incremental error

For some applications, notably batch weighing, where small additions are to be made to or from a large batch, a knowledge of incremental error is advantageous. For this determination to be useful the resolution of the weighing system should be smaller than the expected error.

A4.3.1 Tests to determine incremental error may be performed during the calibration procedure, providing due consideration is given to subsection 4.4.

A4.3.2 At selected loads place a small additional test load in accordance with subsection 4.4, nominally centred on the weighing structure. The value of this load should be appropriate to the normal operating conditions. Record the weighing system output before and after load application. Remove the test load.

A4.3.3 Repeat the test twice more to give three series of readings.

#### **A4.4 Calculation of incremental error**

A4.4.1 Calculate the average value of weighing system output change for each incremental load applied.

A4.4.2 Compute the difference between this value and the value of the load change and express this difference either in absolute weight terms or as a percentage of the incremental load applied.

## ANNEX V

### A5. UNCERTAINTY OF CALIBRATION RESULTS

[UKAS document M3003](#) gives comprehensive information on the estimation of measurement uncertainty – the following example is based on the calculations given in section K5 of that document. The uncertainty estimation for the calibration of the weighing system should follow this general approach, but additional contributions may need taking into account, based on the system's specific details.

#### Calibration of a weighing machine of 1000 kg capacity with a displayed resolution of 0.1 kg

The calibration, following the three run method (see subsection 4.4.2.1), is carried out using weights of OIML Class M<sub>3</sub>, and the results given in the following table are obtained:

LOAD APPLIED	DISPLAYED VALUE			INDICATION (ZERO ADJUSTED)			MEAN	ST DEV
kg	kg			kg			kg	kg
	Test 1	Test 2	Test 3	Test 1	Test 2	Test 3		
0	0.0	0.1	0.1	0.0	0.0	0.0		
125	125.4	125.2	125.6	125.4	125.1	125.5	125.3	0.208
325	325.2	325.5	325.6	325.2	325.4	325.5	325.4	0.153
400	400.3	400.5	400.8	400.3	400.4	400.7	400.5	0.208
600	600.8	600.6	600.9	600.8	600.5	600.8	600.7	0.173
800	800.3	800.5	800.3	800.3	800.4	800.2	800.3	0.100
1 000	1 000.5	1 000.6	1 000.5	1 000.5	1 000.5	1 000.4	1 000.5	0.058
0	0.2	0.1	0.1	0.2	0.0	0.0		

The following uncertainty calculation is carried out at the minimum calibration load of 125 kg – a similar calculation can be carried out at each of the other five applied load levels. The machine indications are obtained from:

Indication  $I = \text{Sensitivity} \times (W_s + D_s + B_a) + \delta I_0 + \delta I_i + R_i$  where:

$W_s$  = weight of the standard

$D_s$  = drift of standard weight since last calibration

$B_a$  = correction for air buoyancy

$\delta I_0$  = effect of rounding the value to one decimal place at zero load

$\delta I_i$  = effect of rounding the value to one decimal place at applied load

$R_i$  = effect of repeatability of the indication

The calibration certificate for the stainless steel 125 kg standard mass gives an uncertainty of 0.062 5 kg at a confidence level of approximately 95 % (coverage factor  $k = 2$ ).

No correction is made for drift, but the standard weight's calibration interval is set so as to limit the drift to  $\pm 0.02$  kg. The probability distribution is assumed to be rectangular.

No correction is made for air buoyancy. As air density in the UK is unlikely to differ from the value of  $1.2 \text{ kg}\cdot\text{m}^{-3}$  used in the calculation of conventional mass by more than  $0.1 \text{ kg}\cdot\text{m}^{-3}$ , with a subsequent effect on generated force of 12.5 ppm, the expanded uncertainty associated with the effect of air buoyancy changes on applied load is estimated as 12.5 ppm, with a rectangular distribution.

No correction is made for rounding due to the resolution of the digital display of the machine. The least significant digit on the range being calibrated corresponds to 0.1 kg and there is therefore a possible rounding error of  $\pm 0.05$  kg, both at zero load and at applied load. The probability distribution for both is assumed to be rectangular.

The repeatability of the machine was established from a series of  $n$  readings (Type A evaluation, where  $n = 3$ ), which gave a standard deviation  $s(W_R)$  of 0.208 kg. The number of degrees of freedom for this evaluation is 2, i.e.  $n - 1$ .

## Uncertainty budget

Symbol	Source of uncertainty <sup>(1)</sup>	Value <sup>(2)</sup> kg	Probability distribution <sup>(3)</sup>	Divisor <sup>(4)</sup>	$c_i$ <sup>(5)</sup>	$u_i(I)$ <sup>(6)</sup> kg	$\nu_i$ or $\nu_{\text{eff}}$ <sup>(7)</sup>
$W_s$	Calibration of standard weight	0.062 5	Normal	2.0	1.0	0.031	$\infty$
$D_s$	Drift since last calibration	0.020 0	Rectangular	$\sqrt{3}$	1.0	0.012	$\infty$
$B_a$	Air buoyancy (12.5 ppm of nominal value)	0.001 6	Rectangular	$\sqrt{3}$	1.0	0.001	$\infty$
$\delta I_0$	Resolution (at zero load)	0.100 0	Rectangular	$\sqrt{3}$	1.0	0.058	$\infty$
$\delta I_i$	Resolution (at applied load)	0.100 0	Rectangular	$\sqrt{3}$	1.0	0.058	$\infty$
$R_i$	Repeatability of indication	0.208 2	Normal	1.0	1.0	0.208	2
$u(I)$	Combined standard uncertainty		Normal			0.23 <sup>(8)</sup>	2.78 <sup>(9)</sup>
$U$	Expanded uncertainty		Normal ( $k = 3.47$ ) <sup>(10)</sup>			0.78 <sup>(11)</sup>	

<sup>(1)</sup> This column lists the individual sources of uncertainty which can affect the indicated measurement

<sup>(2)</sup> This column apportions a range (and associated unit) to the magnitude of this uncertainty component

<sup>(3)</sup> This column defines how the uncertainty is likely to vary within its specified range

<sup>(4)</sup> This column specifies the value, dependent on the underlying distribution, that the range needs to be divided by to determine a standard uncertainty for this particular contribution – note that a normally-distributed contribution may require a divisor of 2 (if, for example, the range is determined from a calibration certificate with a specified coverage factor of 2) or a divisor of 1 (if the contribution is a Type A standard deviation of a set of observations)

<sup>(5)</sup> This column gives the sensitivity coefficient ( $c_i$ ) required to convert the standard uncertainty into the unit in which the combination of the individual components is to be carried out – in this case, all measurements and calculation are given in kg, so all sensitivity coefficients are equal to 1

<sup>(6)</sup> The standard uncertainty associated with the indication for each uncertainty source  $u_i(I)$  is determined by dividing its value by the divisor associated with its probability distribution then multiplying by the sensitivity coefficient required to express it in the correct unit of measurement

<sup>(7)</sup> This column gives the degrees of freedom ( $\nu_i$ ) associated with each uncertainty contribution. For Type A contributions (determined from a series of  $n$  observations), this is equal to  $n-1$ . For Type B components (for which uncertainty is evaluated by other means), it can be assumed that this value is equal to infinity

<sup>(8)</sup> The combined standard uncertainty is the sum, in quadrature, of the individual standard uncertainty components

<sup>(9)</sup> The value of the effective degrees of freedom ( $\nu_{\text{eff}}$ ) is calculated from the Welch-Satterthwaite equation, which takes into account the degrees of freedom associated with any Type A uncertainty contributions and their relative magnitude when compared with Type B components

<sup>(10)</sup> The coverage factor  $k$  is based on the  $t$ -distribution for the effective degrees of freedom to give a level of confidence of approximately 95 %

<sup>(11)</sup> The expanded uncertainty is obtained by multiplying the combined standard uncertainty by the coverage factor  $k$

## Reported result

For an applied weight of 125 kg the indication of the weighing machine was **125.3 kg  $\pm$  0.8 kg**.

The reported expanded uncertainty is based on a standard uncertainty multiplied by a coverage factor  $k = 3.47$ , providing a coverage probability of approximately 95 %. The uncertainty evaluation has been carried out in accordance with UKAS requirements.

## ANNEX VI

### A6. EXAMPLE OF CALIBRATION CERTIFICATE

May include additional information see subsection 4.10.

<b>CALIBRATION CERTIFICATE</b>		<i>Company Logo Here</i>
ISSUED BY SPECIALIST CALIBRATION CO. LTD. DATE OF ISSUE: 26 April 2011      SERIAL NUMBER: 23456		Page 1 of 3 pages
COMPANY ADDRESS		
<b>COMPANY CERTIFICATION</b>		<b>Approved signatory</b>
<b>FOR:</b> The Bulk Process Weighing Co. Ltd. Industrial Park Newtown XX12 Y34	<b>SYSTEM LOCATION:</b> At their Newtown site	
<b>CUSTOMER REF:</b> ABPC1234	<b>OUR REF:</b> ACL4321	
<b>DESCRIPTION:</b> An industrial process weighing system comprising of a hopper supported on four shear beam load cells of type SWC-LC of 1000 kg rated load and a digital weight indicator type SWC-WI all supplied by Specialist Weighing Co. Ltd. The system is used for weighing of several ingredients charged into the hopper. The weight indicator is configured to display 1000.0 × 0.1 kg.		
<b>IDENTIFICATION:</b>	Line Bin No. 5 Load Cells : 123456, 234567, 345678, LC1 (unidentified) Weight Indicator : SWC-4321	
<b>DATE OF CALIBRATION:</b> 19 April 2011		
<b>CALIBRATED BY:</b> Mr A Smith		
<b><i>THIS SYSTEM WAS PREVIOUSLY CALIBRATED BY SPECIALIST CALIBRATION CO. LTD. ON 25.04.2010, CERTIFICATE SERIAL NO. 01234</i></b>		
<b>METHOD:</b> Prior to calibration the weighing system was checked for integrity and suitability for calibration. The system was allowed to warm up under power for not less than 12 hours. The zero tracking function was disabled before commencing the calibration.  A platform was suspended from the flange of the weigh vessel by a set of chains and a series of loads were applied in ascending order up to 1000 kg by placing standard weights on the platform. The load was then removed and this procedure was repeated twice more.  The indicated readings are given below.		
<i>The procedures performed during this calibration are in accordance with the Institute of Measurement and Control, Code of Practice Document number WGC0496, except where stated.</i>		

## A6. EXAMPLE OF CALIBRATION CERTIFICATE (continued)

May include additional information see subsection 4.10.

<b>CALIBRATION CERTIFICATE</b>		<i>Serial Number</i> 23456		
ISSUED BY SPECIALIST CALIBRATION CO. LTD.		Page 2 of 3 pages		
<b>TRACEABILITY:</b>				
Platform identification no. 949, calibration certificate no. TR6005, calibrated with weighing system having UKAS calibration certificate no. 00199.				
Set of chains identification no. 940, calibration certificate no. TO5934, calibrated on a weigh scale having UKAS calibration certificate no. 19909.				
Standard weights, UKAS calibration certificate numbers TO3438, TO3439, TO3440 and TO3460 to M <sub>3</sub> grade, OIML International Recommendation R 111.				
<b>RESULTS:</b>				
a. The calibration results reported below are 'as found'. No adjustment has been carried out on the weighing system output.				
Table 1 Recorded results.				
LOAD APPLIED kg	LOAD DISPLAYED kg			
	<u>Test 1</u>	<u>Test 2</u>	<u>Test 3</u>	
0	0.0	0.1	0.1	
125 (chains)	125.4	125.2	125.6	
325 (+ platform)	325.2	325.5	325.6	
400	400.3	400.5	400.8	
600	600.8	600.6	600.9	
800	800.3	800.5	800.3	
1 000	1 000.5	1 000.6	1 000.5	
0	0.2	0.1	0.1	
Table 2 Calculated differences of output after correction for zero load output.				
LOAD APPLIED kg	DIFFERENCES OF OUTPUT kg			
	<u>Test 1</u>	<u>Test 2</u>	<u>Test 3</u>	<u>Average</u>
125 (chains)	125.4	125.1	125.5	125.3
325 (+ platform)	325.2	325.4	325.5	325.4
400	400.3	400.4	400.7	400.5
600	600.8	600.5	600.8	600.7
800	800.3	800.4	800.2	800.3
1 000	1 000.5	1 000.5	1 000.4	1 000.5
Checked				
<i>The procedures performed during this calibration are in accordance with the Institute of Measurement and Control, Code of Practice Document number WGC0496, except where stated.</i>				

## A6. EXAMPLE OF CALIBRATION CERTIFICATE (continued)

May include additional information see subsection 4.10.

<b>CALIBRATION CERTIFICATE</b>				<i>Serial Number</i> 23456		
ISSUED BY SPECIALIST CALIBRATION CO. LTD.				Page 3 of 3 pages		
b. Tests to determine the incremental error were carried out at 600 kg load,						
	<u>Test 1</u>	<u>Test 2</u>	<u>Test 3</u>	<u>Average</u>		
incremental load applied, kg	100.0	100.0	100.0	100.0		
corresponding load indicated, kg	100.1	100.1	100.1	100.1		
<b>UNCERTAINTY OF APPLIED LOAD:</b>						
Considered to be better than $\pm 0.06\%$ .						
<b>PROCESSING OF CALIBRATION DATA:</b>						
Nominal applied load kg	Average displayed value kg	Non-linearity BSLZ %	Non-linearity Terminal %	Repeatability % of span	Expanded uncertainty kg	<i>k</i>
0	0	0.000	0.000			
125	125.3	0.022	0.024	0.04	0.8	3.5
325	325.4	0.018	0.024	0.03	0.5	2.6
400	400.5	0.023	0.030	0.04	0.7	2.9
600	600.7	0.030	0.040	0.03	0.6	2.3
800	800.3	-0.024	-0.010	0.02	0.5	2.0
1 000	1 000.5	-0.017	0.000	0.01	0.6	2.0
For each nominal applied load, the indication of the machine was the average displayed value $\pm$ the expanded uncertainty. The reported expanded uncertainty is based on a standard uncertainty multiplied by the coverage factor <i>k</i> specified in the final column, to provide a coverage probability of approximately 95 %.						
<b>PROCESSING OF TEST DATA:</b>						
At 600 kg load, the incremental error is 0.1 kg for 100 kg incremental load, or						
$\frac{100 - 100.1}{100} \times 100 = -0.1\%$						
<b>OBSERVATIONS:</b>						
1. The tie rods were checked and found to be in satisfactory condition.						
2. Clearances around the vessel and the load cells were checked and found to be satisfactory.						
3. The clearance around the outlet pipe where it goes through the mezzanine floor, is small and may be blocked by debris. This should be regularly checked.						
Checked						
The procedures performed during this calibration are in accordance with the Institute of Measurement and Control, Code of Practice Document number WGC0496, except where stated.						



## ANNEX VII

### A7. CONVERSION FACTORS FOR MASS AND FORCE, AND A LIST OF USEFUL VALUES

#### Mass

Unit	SI Equivalent	Inverse
pound (lb)	0.453 592 37 kg	2.204 62
ton (2 240 lb)	1.016 05 tonne	0.984 203
tonne	1 000 kg	

#### Force

Required unit of force	Factor by which the force in kilonewtons must be multiplied.
kilogram-force(kgf)	101.971 62
pound-force(lbf)	224.808 94
ton-force(tonf)	0.100 361 1

#### List of useful values

a. Values for acceleration due to gravity.

A useful tool for calculating the local value of acceleration due to gravity can be found at: <http://www.ptb.de/cartoweb3/SISproject.php>

g (standard)	9.806 65 m·s <sup>-2</sup>
g (Channel Islands)	9.810 2 m·s <sup>-2</sup>
g (London)	9.811 9 m·s <sup>-2</sup>
g (Birmingham)	9.812 7 m·s <sup>-2</sup>
g (York)	9.814 0 m·s <sup>-2</sup>
g (Edinburgh)	9.816 0 m·s <sup>-2</sup>
g (Shetland Islands)	9.819 5 m·s <sup>-2</sup>

b. Approximate densities of commonly used materials.

Air	1.2 kg·m <sup>-3</sup>
Iron	7 200 kg·m <sup>-3</sup>
Stainless steel	7 850 kg·m <sup>-3</sup>
Sand (dry)	1 600 kg·m <sup>-3</sup>
Alcohol	800 kg·m <sup>-3</sup>
Petroleum products (typical)	800 kg·m <sup>-3</sup>

## BIBLIOGRAPHY

1. [BS EN 45501, Metrological aspects of non-automatic weighing instruments.](#)
2. BS EN ISO 9001, Quality management systems – Requirements.
3. BS EN ISO 10012, Measurement management systems - Requirements for measurement processes and measuring equipment.
4. BS EN ISO/IEC 17025, General requirements for competence of testing and calibration laboratories.
5. [BS 8422, Force measurement - Strain gauge load cell systems - Calibration method.](#)
6. [EURAMET cg-4, Version 2.0, Uncertainty of Force Measurements, March 2011.](#)
7. [InstMC WFMP1010, A Guide to Dynamic Weighing for Industry, October 2010.](#)
8. [InstMC Guide to the Measurement of Force, 1998.](#)
9. [JCGM 100:2008 \(GUM 1995 with minor corrections\), Evaluation of measurement data — Guide to the expression of uncertainty in measurement \(GUM\).](#)
10. [JCGM 200:2008\(E\), International vocabulary of metrology - Basic and general concepts and associated terms \(VIM\).](#)
11. [OIML International Document D 10, 2007, Guidelines for the determination of calibration intervals of measuring instruments.](#)
12. [OIML International Document D 28, 2004, Conventional value of the result of weighing in air.](#)
13. [OIML International Recommendation R 47, 1979, Standard weights for testing of high capacity weighing machines.](#)
14. [OIML International Recommendation R 111-1, 2004, Weights of classes  \$E\_1\$ ,  \$E\_2\$ ,  \$F\_1\$ ,  \$F\_2\$ ,  \$M\_1\$ ,  \$M\_{1-2}\$ ,  \$M\_2\$ ,  \$M\_{2-3}\$ , and  \$M\_3\$  – Metrological and technical requirements.](#)
15. [UKAS LAB14, Calibration of weighing machines, November 2006.](#)
16. [UKAS M3003, The Expression of Uncertainty and Confidence in Measurement, January 2007.](#)